

KAZAN (VOLGA REGION) FEDERAL UNIVERSITY
INSTITUTE OF PHYSICS
DEPARTMENT OF MEDICAL PHYSICS

S.V. Efimov, A.N. Turanov

PRACTICAL WORK
MEDICAL PHYSICS
Part 4. Electricity and magnetism. Part 5. Optics

For English-speaking students of medical, biomedical
and pharmaceutical fields of study

Kazan – 2023

UDC 537; 535

LBC 22.3

Printed on recommendation
of Educational-methodical commission Institute of Physics
of Kazan (Volga Region) Federal University
(Minutes No. 1 dated September 18, 2023)

Authors:

Assistant Professor of the Department of Medical Physics, PhD S.V. Efimov
Professor of the Department of Medical Physics, PhD, Doctor of Technical
Sciences A.N. Turanov

Reviewers:

Senior lecturer of the Department of Medical and biological physics with
informatics and medical equipment of the Kazan State Medical University,
PhD **A.A. Sukhanov**

Senior researcher, Laboratory of Spin Physics and Spin Chemistry,
Zavoisky Physical-Technical Institute, FRC Kazan Scientific Center of RAS,
Ph.D. **Yu.E. Kandrashkin**

E27

Practical work. Medical physics. Part 4. Electricity and magnetism. Part 5.
Optics: Study aid: For English-speaking students of medical, biomedical and
pharmaceutical fields of study / S.V. Efimov, A.N. Turanov. – Kazan: Kazan
University Press, 2023. – 84 p.

Collection of descriptions of laboratory work “Practical work. Medical physics. Part 4.
Electricity and magnetism. Part 5. Optics” is intended for students of foreign groups of medical
specialties of the university, provided by a brief overview, installation manuals, step-by-step
instructions and a list of questions for self-examination.

УДК 537; 535

ББК 22.3

E27

© Kazan University Press, 2023

Table of contents

Part 4. ELECTRICITY AND MAGNETISM.....	5
411. Resistivity of a metallic conductor.....	5
412. Internal resistance of a battery.....	12
413. Poggendorff compensation method of measuring electromotive force	17
414. Resistors connected in parallel and in series	21
421. Equipotential lines of electric fields.....	26
451. Ohm's law in an alternating-current circuit and determination of inductance and capacity.....	32
452. Electric oscillations in an <i>L-R-C</i> series circuit.....	36
464. Semiconductor diodes.....	42
472. Temperature dependence of conductivity of electrolytes.....	45
Part 5. OPTICS.....	49
514. Centered optical systems.....	49
515. Telescope.....	58
517. Refractive index of liquids.....	65
521. Refractive index and dispersion of a prism.....	70
563. Grating spectrometer.....	78
Appendix	83

List of literature

This manual is based on the following textbooks:

Aganov, A.V. Medical Physics Part 1. Mechanics. Molecular physics / A.V. Aganov, K.S. Usachev. – Kazan.: Kazan University Press, 2022. – 280 p.

Young, H.D. University Physics with Modern Physics / H.D. Young, R.A. Freedman. – Pearson Education, Inc.; 15th edition, 2019. – 1600 p.

Serway, R.A. Physics for Scientists and Engineers with Modern Physics / R.A. Serway, J.W. Jewett, Jr. – Cengage Learning, 2018. – 1484 p.

Acknowledgments

We thank the staff of the Department of Medical Physics of the Kazan Federal University. The results of their work have been used to compile this collection.

We also thank the reviewers of this text. Special thanks to the authors of the books listed in the List of literature.

We welcome any feedback from students and professors, especially concerning errors or deficiencies. Please feel free to contact us:

Sergey Efimov and Alex Turanov
sergej.efimov@kpfu.ru anturanov@kpfu.ru

Part 4. ELECTRICITY AND MAGNETISM

411. Resistivity of a metallic conductor

Objective

Conductor resistance measurement; determination of wire material resistivity.

Tasks

Application of direct and indirect methods for measuring resistance.

Ohm's law between two points without EMF sources

If there is a potential difference $\Delta\varphi = \varphi_2 - \varphi_1$ at the terminals of a simple circuit of conductors, an electric current appears in this circuit. The current I passing through a particular branch is proportional to the potential difference $\Delta\varphi$ at its terminals and reciprocal to the resistance R of that conductor. The SI unit of electric current is ampere A and that of resistance is ohm Ω .

$$I = \frac{\Delta\varphi}{R} . \quad (411.1)$$

The value $U = I \cdot R$ is called the voltage drop across the conductor. The SI unit of voltage drop is volt V. If the considered branch does not contain any elements that provide electromotive force (EMF), then the potential difference at the terminals of this branch is equal to the voltage drop across it, i.e. $\Delta\varphi = U$.

If a voltmeter is connected to the points 1 and 2 of a circuit, it will show the potential difference between these points. It is equal to the voltage drop U on the voltmeter itself:

$$U = I_V \cdot R_V , \quad (411.2)$$

where R_V is the resistance of the voltmeter and I_V is the current passing through it.

Resistance of conductors

For a branch of the circuit of length l and constant cross-section S , the chemical composition of which is homogeneous, the resistance R of this conductor is defined as

$$R = \frac{\rho \cdot l}{S} , \quad (411.3)$$

where ρ is the resistivity of the material. Resistivity is numerically equal to the resistance of a conductor of unit length and unit cross-section. It depends on chemical composition and temperature. The SI unit of resistivity is $\Omega \cdot \text{m}$; the unit $\Omega \cdot \text{mm}^2/\text{m}$ is often used, too.

At room temperature, conductors made of chemically pure metals have the lowest resistivity. Alloys of different metals have a higher resistivity, so they are used for high-resistance elements (rheostats, heating elements, shunts, etc.). Resistivity of some materials is given in the Appendix (Table A1).

Resistance measurement methods

The main methods for measuring DC (direct current) resistance are the indirect method, the direct evaluation method, and the bridge method. The choice of the method depends on the expected value of the resistance and the required accuracy. The most universal indirect method is based on the ammeter and voltmeter measurements for a circuit branch. The resistance is derived according to the Ohm's law by Eq. (411.1) and $\Delta\varphi = U$:

$$R = U/I . \quad (411.4)$$

Here U is the potential difference at the terminals of a conductor, and I is the current passing through it, R is the resistance of a conductor. The more accurate bridge circuit method is described in another lab.

A direct method of evaluation is measurement with an ohmmeter. This approach is not very accurate and is mainly used for preliminary evaluation and testing of the commutation circuits.

In the present work, the method of ammeter and voltmeter is studied.

A method for accurate measurement of current

This method always has some error due to the involvement of measuring instruments, which depends on the way these instruments are connected in the circuit.

In Fig. 411.1 (left) the voltmeter pV measures the potential difference $U = \varphi_2 - \varphi_1$ on a series-connected conductor (with the resistance R) and ammeter PA (with the resistance R_A). Therefore, the potential difference between nodes **1** and **2** is equal to the sum of the potential differences on these elements:

$$U = I \cdot R + I \cdot R_A . \quad (411.5)$$

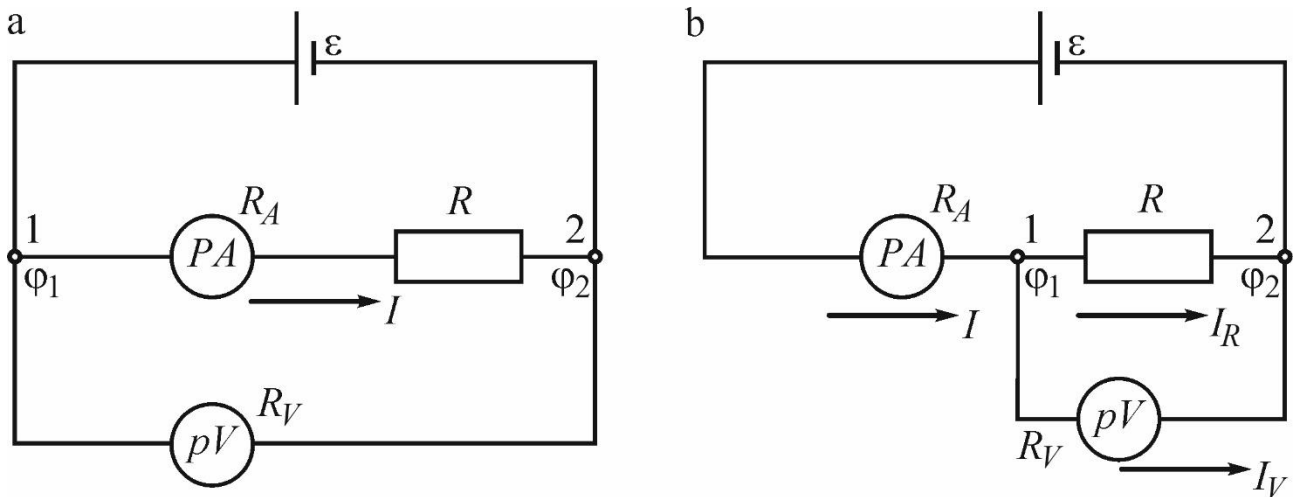

Figure 411.1. Circuits for indirect measurement of resistance

The calculation according to Eq. (411.4) has a systematic error, since here the measured experimental resistance R_e includes the contribution from both the conductor and the ammeter. The correct resistance of the resistor (e.g., a wire), according to Eq. (411.5), can be obtained as

$$R = \frac{U}{I} - R_A , \quad (411.6)$$

where U is the potential difference measured with the voltmeter.

Thus, the methodological error is the difference $\Delta R = R_e - R = R_A$. The internal resistance of the ammeter is typically small (and one can assume $R \approx R_e$), Thus, the smaller is the value R_A compared

to the measuring resistance R , the better is the accuracy. The relative error of this method is

$$\varepsilon_{m1} = \left| \frac{\Delta R}{R} \right| \approx \frac{R_A}{R_e}. \quad (411.7)$$

An ideal ammeter has zero internal resistance.

A method for accurate measurement of voltage

In Fig. 411.1 (right) the total current passing through resistor R and voltmeter PV (with an internal resistance R_V) is measured. The potential difference in this case is the same for both, the conductor and the voltmeter; let us denote it U (voltmeter reading). The Ohm's law in this case determines the following separate currents I_R and I_V passing through the resistor and voltmeter, respectively: $I_R = U/R$, $I_V = U/R_V$. The measured current is $I = I_R + I_V$, and hence

$$I_R = I - I_V = I - \frac{U}{R_V}. \quad (411.8)$$

The resistance of the conductor R can be found by Eq. (411.4) from the reading of the measuring gauges, if the current passing through the voltmeter can be included in the calculation. So, resistance R is

$$R = \frac{U}{I_R} = \frac{U/I}{1 - U/(IR_V)} = \frac{R_e}{1 - R_e/R_V}. \quad (411.9)$$

The internal resistance of a voltmeter is usually relatively high, so it can be assumed that $R \approx R_e$, and $R_V - R_e \approx R_V$. Then the relative error of this method

$$\varepsilon_{m2} = \left| \frac{\Delta R}{R} \right| = \frac{R_e - R}{R} = \frac{R_e^2}{R \cdot (R_V - R_e)} \approx \frac{R_e}{R_V}. \quad (411.10)$$

Eq. (411.10) shows that the higher is the internal resistance of a voltmeter, the higher is the accuracy (the smaller the error ε). By this reason, analog electronic and digital voltmeters are high-resistance devices.

There is a methodological inaccuracy in the use of Eq. (411.4). It can be eliminated if the internal resistances of the instruments are known.

The instrumental errors, which depend on the design of the devices and their accuracy class, are another source of the systematic error; they are not studied in this lab.

Experimental setup

Experimental setup FRM-01 is shown in Fig. 411.2 (left). The basis 1 holds the column 2 with the millimetre gauge 3. Two fixed supports 4 and one movable support 5 are attached to the column; the support 5 can be moved and fixed in any position. A nichrome (a family of alloys of nickel Ni and chromium Cr (and occasionally iron Fe)) wire 6 is strung between the upper and bottom supports 4. A contact on the movable support provides a good galvanic connection with the wire. A marker (notch) on the support 5 is used to determine the length of measured nichrome wire. The upper, lower, and

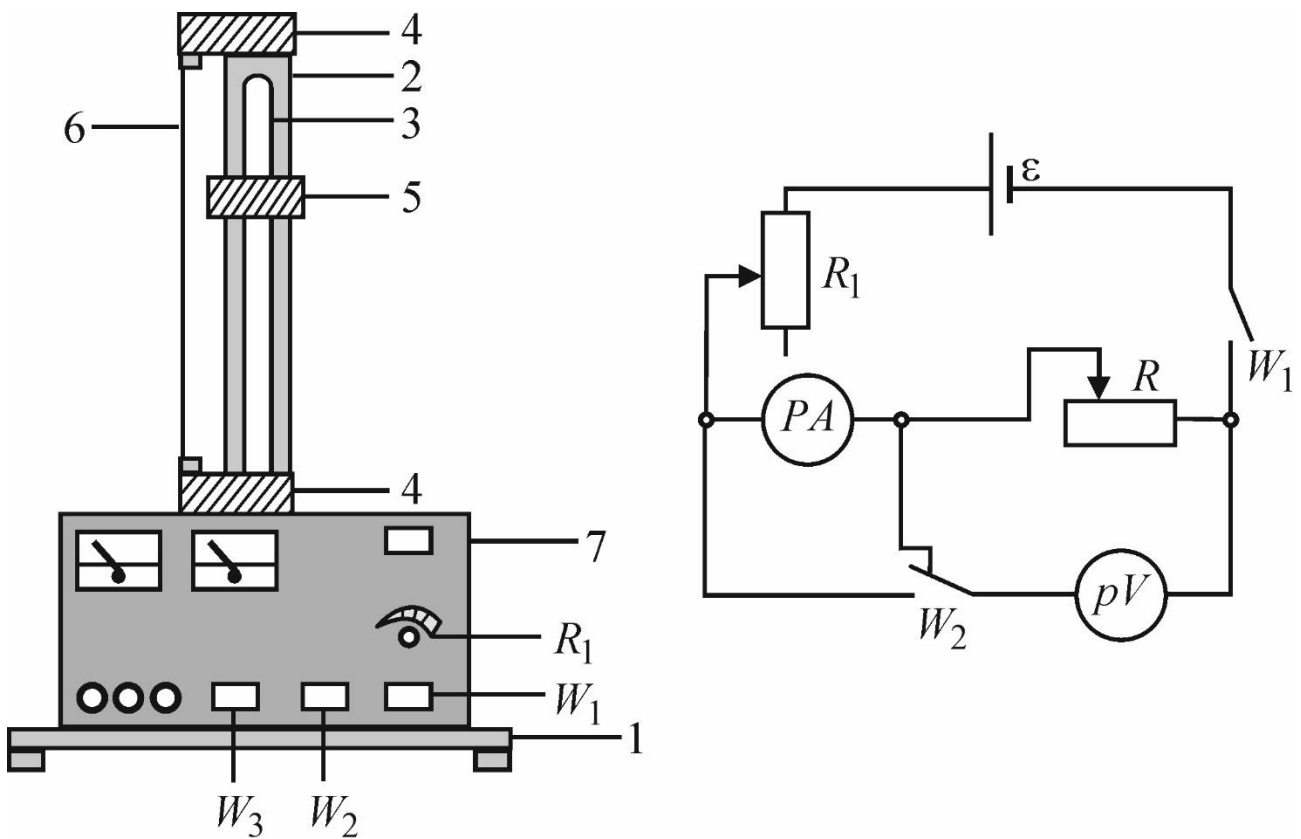

Figure 411.2. Experimental setup

A contact on the movable support provides a good galvanic connection with the wire. A marker (notch) on the support 5 is used to determine the length of measured nichrome wire. The upper, lower, and

middle (movable) contacts are connected to the measuring unit 7 by low-resistance wires.

On the front side of the block 7 there are panels of the ammeter PA and the voltmeter pV , the power switch button W_1 (to turn on/out the setup), the buttons W_2 and W_3 , and the rheostat knob R_1 . When the button W_3 is released, the wire can be used for measurement employing the bridge circuit; when it is pressed, the active resistance of the wire is measured using the ammeter and voltmeter.

If the button W_2 is released, the method with accurate current measurement is used (Fig. 411.1 (left)); when it is pressed, the method with accurate voltage measurement is used (Fig. 411.1 (right)).

Algorithm of measurements

1. Prepare the table for the measurement results.

N_0	I_i, mA	U_i, V	$R_{e\ i}, \Omega$	R_i, Ω
...				

2. Set the knob R_1 of the current regulator to the minimal value (turn counter clockwise until it stops). By moving the support 5, set an arbitrary wire length l . Record its length and the wire diameter d (see at the setup or measuring it by a micrometer). The internal resistances of the measuring devices R_A and R_V are indicated on the setup.

3. Turn on the setup. Make five resistance measurements at various currents (turning the knob R_1 at various angles) by the method with accurate current measurement.

4. Prepare another table. Push the button W_2 and take a series of measurements by the method with accurate voltage measurement.

5. Turn off the setup.

6. Calculate the preliminary (uncorrected) ($R_{e\ i}$) and corrected (R_i) wire resistance values using Eqs. (411.4), (411.6), and (411.9), as well as their average values $\langle R_e \rangle$ and $\langle R \rangle$ for each method of measuring.

7. Determine the errors ε_{m1} and ε_{m2} according to Eqs. (411.7) and (411.10) for each method. Find which scheme is more accurate.

8. Derive the resistivity ρ of the nichrome wire according to Eq. (411.3). For this, take the $\langle R \rangle$ value from the measuring approach, which turned out to have the smallest error ε .

9. Analyse the result.

Questions

1. What is an electric charge? What is an electric field? Describe their properties.

2. What is an electric current? How are the current and current density measured (give the definitions, formulas, units of measurement)? How is the direction of the current defined?

3. What are the conditions necessary for the existence of an electric current?

4. What materials are conductors? Give some examples. What is charge carrier in these materials?

5. Describe Ohm's law for a circuit without EMF sources (equation, units).

6. What is the physical meaning of the conductor resistance? On what factors does the resistance depend?

7. What is resistivity (also known as specific resistance) of a conductor?

8. What devices are used to measure the currents and voltages in a circuit? How should they be connected; what is their resistance?

9. Derive working formulas for finding resistance in methods with accurate measurement of current or voltage.

412. Internal resistance of a battery

Objective

Study and measurement of the internal resistance of the battery.

Tasks

Measure of the voltage at the battery terminal as a function of the current passing through a load resistor.

Determine the internal resistance, the open-circuit voltage, and the short-circuit current of the battery.

The open-circuit voltage U_0 generated in a battery is generally different from the voltage U at the terminals when a current I is drawn from the battery. For the maximal current (short-circuit current I_S) that can be drawn from the battery, the voltage at the terminals drops to zero. This means that there must be an internal resistance R_i in the battery that causes the voltage drop. This resistance is called the internal resistance of the battery.

In the experiment, a rheostat is connected to a battery as an ohmic load for determining the internal resistance. The voltage at the terminals U of the battery is measured for different loads and plotted against the current I passing through the load resistor. Assuming that the internal resistance R_i is constant, a straight line is fitted to the measured values according to

$$U = U_0 - R_i \cdot I. \quad (412.1)$$

Internal resistance can be determined from the slope of a straight line. Fig. 412.1 (left) demonstrates a typical dependency of this kind. Since R_i is constant, the short-circuit current is

$$I_S = \frac{U_0}{R_i} \quad (412.2)$$

The supplied power

$$P = U \cdot I, \quad (412.3)$$

is shown in Fig. 412.1 (right) versus load resistance.

The relationship between the voltage drop U across the rheostat and the current I in the rheostat is

$$R = \frac{U}{I} \quad (412.4)$$

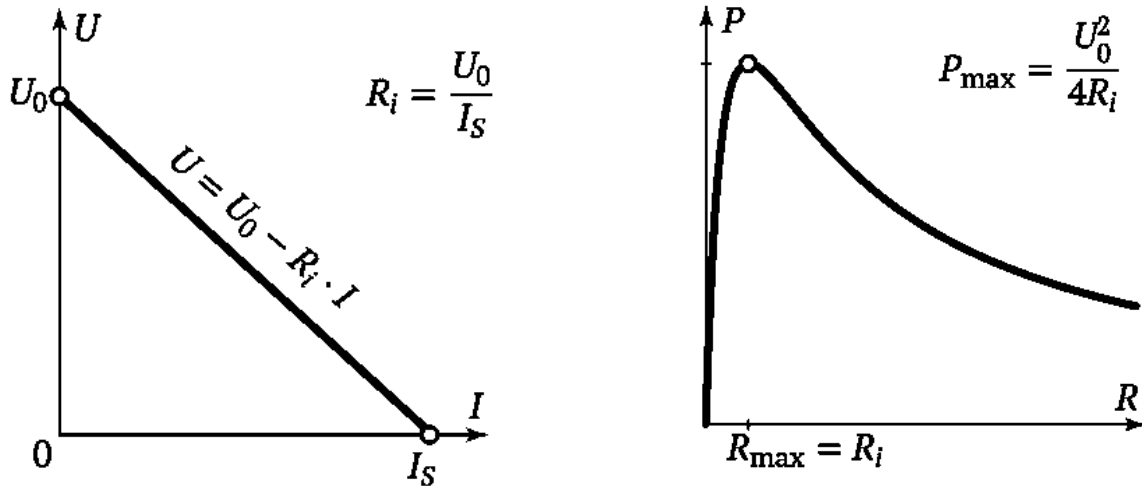

Figure 412.1. Dependencies of U vs. I and P in the rheostat vs. R for the circuit

Eqs. (412.1), (412.3), and (412.4) imply:

$$P = U_0^2 \frac{R}{(R+R_i)^2} \quad (412.5)$$

When the load resistance R is equal to the internal resistance R_i , the input power P reaches the maximum

$$P_{\max} = \frac{U_0^2}{4 \cdot R_i} = \frac{U_0 \cdot I_S}{4} \quad (412.6)$$

At maximum power, the voltage at the terminals corresponds to half of open-circuit voltage, i.e.

$$U_{\max} = U_0 / 2, \quad (412.7)$$

and the consumed current is equal to half of the short-circuit current, i.e.

$$I_{\max} = \frac{U_0}{2R_i} = \frac{I_S}{2} \quad (412.8)$$

Experimental setup

Battery 1.5 V, 12 V or another

Rheostat 10 Ω

Voltmeter and ammeter

Connecting wires

Multimeters LD analog 20 can be used as a voltmeter and ammeter in the experiment. Before connecting devices to the circuit, select the measurement limits as specified below (Fig. 412.2). The operating mode (current or voltage measurement, ranges, AC or DC type) can be set by turning the switch.

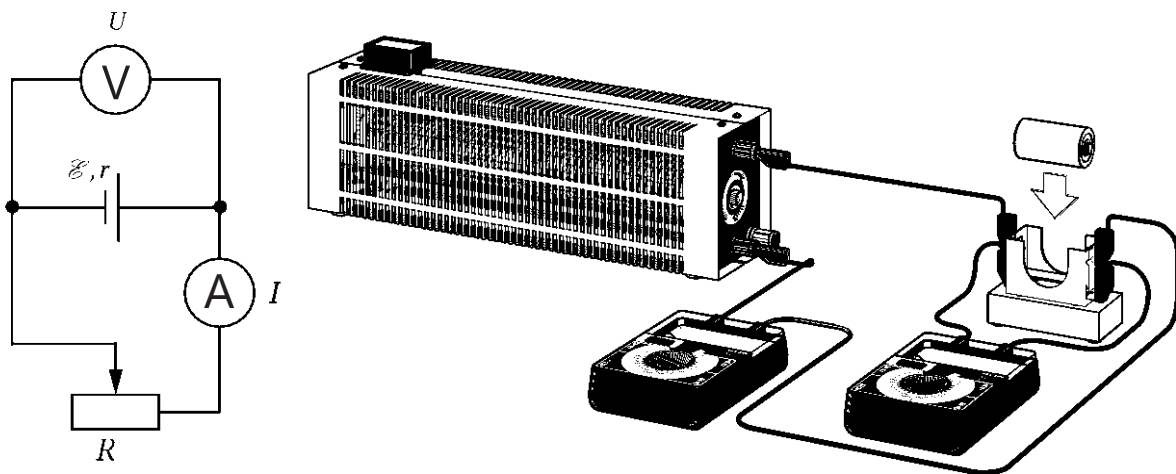

Figure 412.2 Experimental setup

Algorithm of measurements

1. Disconnect the circuit.
2. Assemble the circuit according to Fig. 412.2: connect the battery (power source), the ammeter, and the rheostat in series but do not close the circuit yet.
3. Connect the voltmeter to the sockets of the battery (Fig. 412.2).
4. Set measurement ranges 3 V DC on the voltmeter and 3 A DC on the ammeter.
5. Connect the circuit and adjust the rheostat so that the smallest possible current pass through the ammeter.
6. Read the current I and the voltage U , and record them into the table.

U, V	I, A	P, W	R, Ω	Efficiency η
...				

7. By changing the load resistance, increase the current gradually up to a maximum of 1 A, each time reading the current and the voltage quickly.

8. After completing a series of measurements, open the circuit.

9. Build the plot of the voltage U vs. the current I . From the slope of the straight line, obtain short-circuit current I_s , open-circuit voltage U_0 , and determine the internal resistance R_i .

10. Use Eqs. (412.3) and (412.4) to determine the supplied power and the load resistance. Build the plot of the power P vs. the resistance R .

11. Calculate the efficiency of the used electric power as $\eta = R/(R+R_i)$ for every load R and fill in the last column in the table.

12. Analyse your results and draw conclusions. How can be provided the best efficiency η or the maximal power P released in the load?

Questions

1. What is an electric charge? What is current and current density? How is the direction of current defined?

2. How does the current manifest itself (thermal, chemical, magnetic actions)?

3. What types of current are called direct and alternating? Plot the time dependence of the current in both cases.

4. What are the conditions necessary for the existence of a current?

5. Why cannot the electrostatic field of charged particles maintain constant current in a circuit?

6. What are called “external forces”? What role do they play? Definition, equation, units of electromotive force (EMF).

7. Ohm’s law for a circuit with a power source(s). How is the sign of the EMF defined in this equation?

8. What is the reason of the internal resistance of a battery?

9. Power of heating generated by an electrical conductor. Joule's first law.

10. Definition, equation, units of electric current power.

11. Chemical sources of electric current, the principle of operation.

413. Poggendorff compensation method of measuring electromotive force

Objective

Electromotive force study.

Tasks

Measurement of the electromotive force by the compensation method.

Kirchhoff’s rules are useful techniques to compute the currents and voltages in branched electric circuits:

Junction rule: the algebraic sum of the currents in any junction is zero. Typically, incoming currents are considered positive; for example, at point A in Fig. 413.1 $I_1 > 0$ and $I_2 > 0$, but $I < 0$.

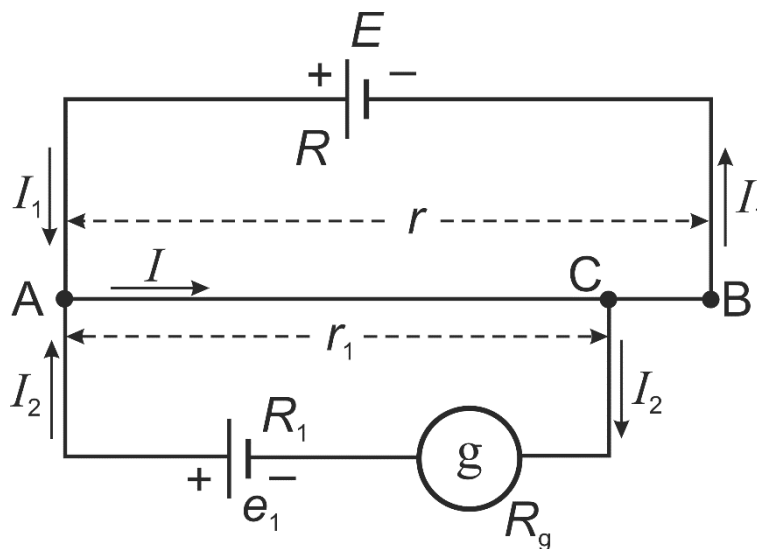

Figure 413.1. Circuit diagram of the experimental setup

Loop rule: the algebraic sum of the potential differences in any closed loop (including those associated with electromotive forces and those of resistive elements) must equal zero. It is necessary to determine “the direction” of the loop. Currents that pass in the same direction, and voltages that cause currents which pass in the same direction, should be considered positive, and those in the opposite direction should be

considered negative. For example, a clockwise direction can be assumed to be positive. Let us choose two loops in the circuit shown in Fig. 413.1: loop I will be AEBCA, and loop II will be ACe₁A. Then, I_2 and I turn out to be “positive” in the loop II, while I_1 and I will be “negative” in the loop I.

Note that the true directions of the currents may not be known at the beginning of the calculations. Then it may happen that one gets as a result a negative value for some currents; this means that their direction is opposite to that which was arbitrarily chosen at the beginning.

A mathematical representation of Kirchhoff’s rules is:

$$\sum I_k = 0 ,$$

$$\sum I_k R_k = \sum E_k .$$

In the particular case shown in Fig. 414.1, these equations can be rewritten as

$$\left\{ \begin{array}{l} I_1 + I_2 - I = 0, \quad (413.1)(\text{point A}) \\ -E = -I_1 \cdot (R + (r - r_1)) - I \cdot r_1, \quad (413.2) \quad (\text{loop I}), \\ e_1 = I_2 \cdot (R_1 + R_g) + I \cdot r_1. \quad (413.3)(\text{loop II}): \end{array} \right.$$

here R is the resistance of a part of the circuit AEB (in general case, but for very low resistance of the wires, it can be considered as the internal resistance of the current source E), R_1 is the resistance of the Ae₁C branch without taking into account the resistance of the galvanometer (denoted as R_g), r is the resistance of the measuring wire AB, and r_1 is the resistance of the wire’s segment AC.

Electromotive force (EMF) is the value of the work per coulomb of charge passing through a non-electrostatic source (such as a chemical source). The SI unit of EMF is the same as for potential, the volt V.

The element with EMF E is connected to the wire at points A and B, and the element with EMF e_1 is connected to the points A and C (slider) with the same polarity (Fig. 413.1). If the galvanometer in the circuit containing the element e_1 does not detect current, i.e. $I_2 = 0$, then $I_1 = I$ and

Eqs. (413.2) and (413.3) can be rewritten as $E = I \cdot (R + r)$ and $e_1 = I \cdot r_1$. From these two relations, we can derive that

$$e_1 = \frac{Er_1}{R + r} \quad (413.4)$$

If the source e_1 is replaced by another element e_2 , then the new resistance of the AC branch should be adjusted to return the reading of the galvanometer I_2 to zero. If this new resistance is equal to r_2 , then

$e_2 = \frac{Er_2}{R + r}$. Dividing the last two equations by each other, we get the ratio

$$\frac{e_1}{e_2} = \frac{r_1}{r_2} \quad (413.5)$$

The resistances r_1 and r_2 are proportional to the corresponding lengths l_1 and l_2 of the branches of the rheochord AB, made of a uniform wire of constant cross-section (Eq. (411.3)). As a result, we get the working equation:

$$e_1 = e_2 \frac{l_1}{l_2} \quad (413.6)$$

For element e_2 , a standard source is used, the EMF of which changes negligibly little over time. The Weston standard cell (normal Weston cadmium cell) is often used for this purpose. Its EMF at 20°C is 1.0183 V and is practically independent of temperature near room temperature: the decrease in EMF is less than 10^{-4} V per 1°C increase.

The compensation method has the following advantages. (1) The currents passing through the compared cells (e_1 and e_2) are close to zero, so the potential difference inside the cell (which decreases the difference of potentials at the cell contacts) is negligible. Sensitive galvanometers allow decreasing the current to the order of $10^{-9} - 10^{-10}$ A. Difference of potentials between terminals of wire does not play any role. (2) The galvanometer reads zero and needs no calibration. The resistances r_1 and r_2 in Eq. (413.5) can be determined with the relative accuracy level of 10^{-2} %. (3) The EMF of the auxiliary source E does not affect the result.

The only requirement for the source is the stability of the value of E during the measurements; in addition, E should be greater than e_1 and e_2 .

Experimental setup

The circuit for determining the EMF of a cell is shown in Fig. 413.2. E is the auxiliary current source, AB is the rheochord, C is the rheochord slider, e_2 is the standard cell ($e_2 = 1.0183$ V), g is the galvanometer operating as a null-indicator, \mathbf{K}_1 and \mathbf{K}_2 are the single- and double-current keys, \mathbf{K}_3 is the button for short-term activation of the galvanometer. The resistance box R_m is used to prevent the standard cell from delivering unacceptably high power.

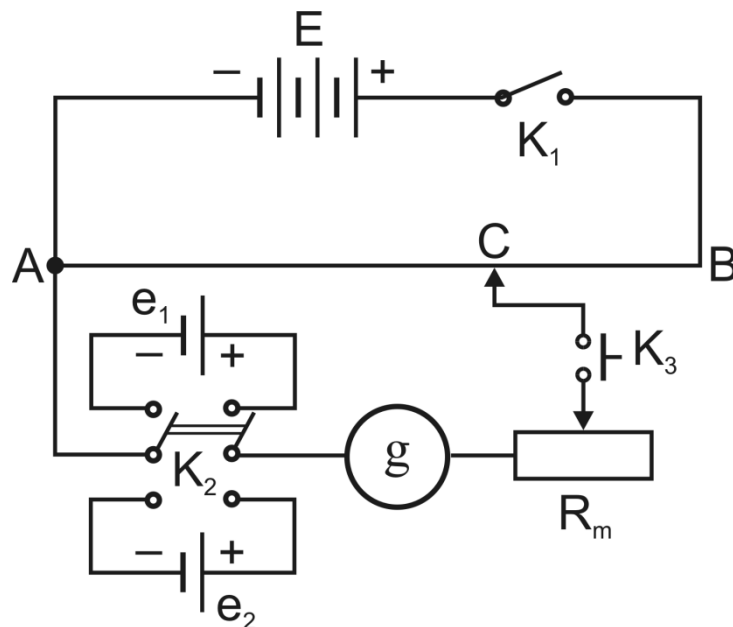

Figure 413.2. Circuit of experimental setup

Algorithm of measurements

1. If necessary, assemble the circuit according to Fig. 413.2. All measurements should be done quickly to obtain accurate results (don't press the button \mathbf{K}_3 for too long). When assembling the circuit, check the polarity of the cells! Choose the maximal resistance R_m in the box. Set the slider C to the middle position of the rheochord and connect the standard cell e_2 with the key \mathbf{K}_2 .

2. Turn on the key \mathbf{K}_1 .

3. Reduce the resistance R_m in the box and press the button \mathbf{K}_3 quickly. Look how the galvanometer's arrow jumps from the zero position: to the left or to the right, quickly or slowly, and just at a small angle. By moving the slider up and down, find the position of the slider C, which compensates the current for the standard cell. In this case, the galvanometer should show the zero current even at $R_m = 0$. Measure the length $AC = l_2$ using the setup gauge.

4. Return R_m to its maximal value and connect the cell e_1 by switching the key \mathbf{K}_2 to another position. As in step 3, compensate the EMF e_1 and measure the corresponding rheochord length $AC = l_1$.

5. Calculate the EMF of the investigated source using Eq. (413.6).

6. Analyse your results.

Questions

1. What is an electric charge? What is current and current density? How is the direction of current defined?

2. Conditions necessary for the existence of a current.

3. Why cannot the electrostatic field of charged particles maintain constant current in a circuit?

4. What is called "external forces"? What role do they play? Definition, equation, units of electromotive force (EMF).

5. Ohm's law for a circuit with a power source(s). How is the sign of the EMF defined in this equation?

6. Why does the potential difference measured across the poles of a power source depend on the load? When can the potential difference measured in this way be considered equal to the EMF?

7. Sources of direct electric current. Standard cell.

8. Methods of measuring EMF. Advantages of the compensation method.

9. Kirchhoff's rules. What is the physical background of the junction rule and the loop rule?

10. Circuit of the experimental setup. Deriving the working equation.

414. Resistors connected in parallel and in series

Objective

Studying resistors connected in parallel and in series. Kirchhoff's rules.

Tasks

Determine the total resistance of resistors connected in parallel.

Determine the total resistance of series-connected resistors.

Kirchhoff's rules are useful techniques to compute the currents and voltages in branched electric circuits:

Junction rule: the algebraic sum of the currents in any junction is zero.

Loop rule: the algebraic sum of the potential differences in any closed loop (including those associated with the electromotive forces and those of the resistive elements) must equal zero.

It is necessary to determine "the direction" of the loop. Currents that pass in the same direction, and voltages that cause currents which pass in the same direction, should be considered positive, and in the opposite direction should be considered negative.

We can check the validity of Kirchhoff's rules in electric circuits with resistors connected in parallel and in series.

The voltage U is the same at terminals of every branch of the circuit with parallel connection of the resistors R_1, R_2, \dots, R_n . According to the junction rule, the algebraic sum of the currents I_1, I_2, \dots, I_n equals to the total current through the resistors.

$$I = I_1 + I_2 + \dots + I_n. \quad (414.1)$$

Thus

$$\frac{U}{R} = \frac{U}{R_1} + \frac{U}{R_2} + \dots + \frac{U}{R_n},$$

and hence for the total resistance R :

$$\frac{1}{R} = \frac{1}{R_1} + \frac{1}{R_2} + \dots + \frac{1}{R_n}. \quad (414.2)$$

The current I is the same at each point of the electric circuit with

series-connected resistors R_1, R_2, \dots, R_n . According to the loop rule, the sum of the potential differences U_1, U_2, \dots, U_n at the terminals of resistors equals to the potential difference of the connected power source.

$$U = U_1 + U_2 + \dots + U_n. \quad (414.3)$$

Thus

$$I \cdot R = I \cdot R_1 + I \cdot R_2 + \dots + I \cdot R_n,$$

and the total resistance R equals:

$$R = R_1 + R_2 + \dots + R_n. \quad (414.4)$$

Experimental setup

Plug-in board DIN A4

Resistor 220 Ω , 2 W

Resistor 330 Ω , 2 W

Resistor 470 Ω , 1.4 W

Resistor 1 k Ω , 2 W

Resistor 5.6 Ω , 2 W

Resistor 10 k Ω , 0.5 W

Resistor 100 k Ω , 0.5 W

Set 10 bridging plugs

DC power supply, 0 \pm 15 V

Multimeter LDanalog 20 (2 pts.)

Pairs of cables 50 cm, red/blue (3 pts.)

Algorithm of measurements

Multimeters LDanalog 20 should be used as a voltmeter and ammeter in the experiment. Before connecting devices to the circuit, select the measurement limits as specified below. The operating mode (current or voltage measurement, ranges, AC or DC type) can be set by turning the switch.

1. Assemble the electric circuit as shown in Fig. 414. Please note that the wires to the power source must be connected to the «+» and «0» sockets on the front panel (do not use «-» socket). The teacher/engineer

should choose the resistors to measure. Since only two multimeters are used, the voltage drop (task 1) or current (task 2) measuring across the resistors is performed by the same device connected to the appropriate nodes of the circuit.

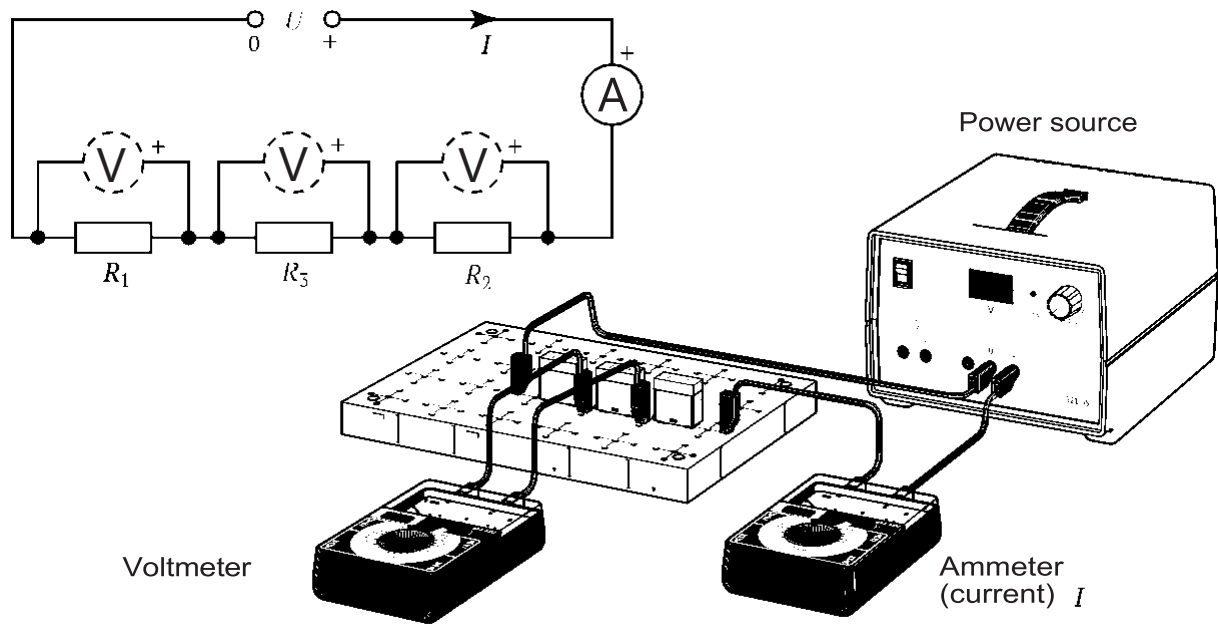

Figure 414.1. Setup for series connection resistors

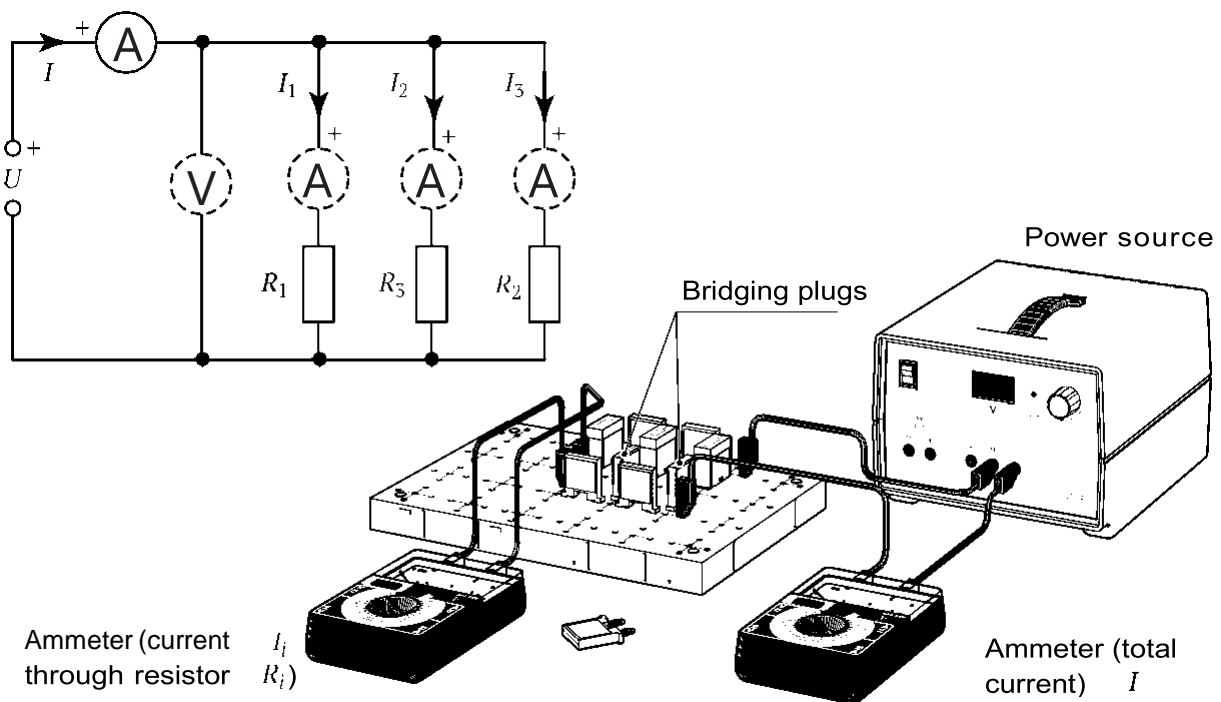

Figure 414.2. Setup for parallel connection of the resistors

2. Set the output voltage $U = 10 \text{ V}$ using the appropriate button on the power source. You are authorized to turn on the power source only after the electric circuit has been checked by a teacher/engineer. Turn on the DC power source.

3. Measure and record down the total current $I = I_{\text{ex}}$ and potential difference U . Determine the experimental value of the circuit resistance $R_{\text{ex}} = U / I_{\text{ex}}$.

Task 1. Determine the total resistance of series-connected resistors.

4. Measure potential differences U_1 , U_2 , and U_3 across each of the resistors R_1 , R_2 , and R_3 . Insert the results into the table:

N	R_i, Ω	U_i, V	$U_{i \text{ theor.}} = R_i \cdot I, \text{V}$
...			

5. Calculate the theoretical value of the resistance R , from Eq. (414.4).

6. Calculate $U_{\Sigma} = U_1 + U_2 + U_3$.

7. Analyse your results (compare R and R_{ex} , U and U_{Σ}) and make conclusions.

Task 2. Determine the total resistance of resistors connected in parallel.

4. Measure currents I_1 , I_2 , and I_3 across each of the resistors R_1 , R_2 , and R_3 . Insert the results into the table:

N	R_i, Ω	I_i, A	$I_i \text{ theor.} = U / R_i, \text{A}$
...			

5. Calculate the theoretical value of the resistance R according to Eq. (414.2).

6. Calculate $I_{\Sigma} = I_1 + I_2 + I_3$.

7. Analyse your results (compare R and R_{ex} , I_{ex} and I_{Σ}) and make conclusions.

Questions

1. What is an electric charge? What is current and current density?
How is the direction of current defined?
2. Conditions necessary for the existence of a current.
3. Why can not the electrostatic field of charged particles maintain constant current in a circuit?
4. What is called “external forces”? What role do they play?
Definition, equation, units of electromotive force (EMF).
5. Ohm’s law for a circuit with a power source(s). How is the sign of the EMF defined in this equation?
6. Why does the potential difference measured across the poles of a power source depend on the load? When can the potential difference measured in this way be considered equal to the EMF?
7. Resistors connected in parallel. Currents, voltages, resistance.
8. Resistors connected in series. Currents, voltages, resistance.
9. Kirchhoff’s rules. What is the physical background of the junction rule and the loop rule?
10. Calculate the parameters of a circuit given by the teacher using the Kirchhoff’s rules.

421. Equipotential lines of electric field

Objective

Explore the space between a pair of electrodes.

Task

Build the plot of cross-sections of equipotential surfaces and electric field lines.

Electric charge is quantized (the SI unit is the coulomb, C); i.e., it is a multiple of the quantity called the elementary charge $e \approx 1.602 \times 10^{-19}$ C. The proton has a positive charge $+e$, and the electron has a negative charge $-e$.

As established by Coulomb's law, the magnitude of the electric force F_{el} between two point charges q_1 and q_2 is directly proportional to the product of the charges and inversely proportional to the square of the distance r between them:

$$F_{el} = \frac{1}{4\pi\epsilon_0} \cdot \frac{1}{\epsilon} \cdot \frac{|q_1 \cdot q_2|}{r^2}. \quad (421.1)$$

Here $\epsilon_0 \approx 8.85 \times 10^{-12}$ C²/N·m² is the electric constant. A reasonable approximation for examples and problems is the value $\frac{1}{4\pi\epsilon_0} = k = 9 \times 10^9$ N·m²/C². The notation $|q_1 \cdot q_2|$ means the absolute value of the charges q_1 and q_2 , and ϵ is the relative permittivity (dielectric constant) of the medium. It is a dimensionless number greater than 1. For example, the relative permittivity of the air $\epsilon_{air} \approx 1.005$.

The force is directed along the line connecting the particles, and is repulsive for charges of the same sign and attractive for charges of the opposite sign. We can introduce a vector \vec{r} directing from q_1 to q_2 . By dividing the vector \vec{r} by its own magnitude (eigenvalue) r , we get a unit vector $\frac{\vec{r}}{r}$ which has the same direction as \vec{r} . Using $\frac{\vec{r}}{r}$ we can rewrite Eq. (421.1) as

$$\vec{F}_{el} = k \cdot \frac{1}{\epsilon} \cdot \frac{|q_1 \cdot q_2|}{r^2} \cdot \frac{\vec{r}}{r}. \quad (421.2)$$

The concept of an electric field was introduced by Michael Faraday. One way to describe the force between charges is to say that the charge changes the surrounding space, producing an electric field \vec{E} . The unit of the electric field in the SI system is volts per meter, V/m. Any charge placed in the field of another charge is subject to the Coulomb force.

To determine the electric field \vec{E} more accurately, consider a small positive test charge q at a given point. As long as everything else remains unchanged, the Coulomb force acting on the test charge q is proportional to the magnitude of q . Then the force per unit charge, \vec{F}/q , does not depend on the magnitude of the charge q , and therefore it can be considered as an electric field \vec{E} at this point:

$$\vec{E} = \frac{\vec{F}}{q} \quad (421.3)$$

The visual representation of the field in terms of lines of force is closely related to the concept of electric field. These are imaginary geometric lines constructed in such a way that the direction of the line, as given by the tangent to the line at each point, always coincides with the direction of the field \vec{E} at that point, or equivalently, is in the direction of the force that would act on a small positive test charge placed at that point. The electric field and the concept of lines of electric force can be used to map out what forces are acting on a charge placed in a particular region of space. Electric field lines begin at positive charges and radiate away from them to negative charges, where they end.

The electrical potential difference $\Delta\phi = \phi_1 - \phi_2$ between two points 1 and 2 is defined as the work A produced by the electric force and required to move a small positive test charge q from one point to another, divided by the magnitude of the test charge, i.e.

$$\Delta\phi = \frac{A}{q}. \quad (421.4)$$

The work, and therefore the potential difference, between two points is independent of the path (trajectory) travelled by the sample charge between the two points. Using the basic definition of work, where work A equals to the force \vec{F} multiplied by the distance $\Delta\vec{r}$

$$A = \vec{F} \cdot \Delta\vec{r} ,$$

a relationship between the electric potential ϕ and the electric field \vec{E} can be found. Note, that while work and potential difference are scalar quantities and are independent of direction and path, the electric field is a vector and it depends on the direction of the force.

$$\Delta\phi = \frac{\vec{F} \cdot \Delta\vec{r}}{q} = \vec{E} \cdot \Delta\vec{r} .$$

If \vec{E} and $\Delta\vec{r}$ are in the same direction, then

$$E = \frac{\Delta\phi}{\Delta r} . \quad (421.5)$$

For situations where the electric field is not uniform, this equation is limited to a small distance increment $d\vec{r}$ and to the potential difference $d\phi$ (here, the letter "d" means the differential of the function). Then the potential difference is found by integrating

$$\Delta\phi = \int d\phi = \int \vec{E} \cdot d\vec{r} .$$

The direction of the electric field is parallel and opposite to the direction in which the electric potential increases the most. In calculus, the operator called the gradient, denoted by the symbol ∇ , is introduced to denote changes to be made in the direction in which the change is greatest. By definition, $\nabla f = \frac{\partial f}{\partial x} \cdot \vec{i} + \frac{\partial f}{\partial y} \cdot \vec{j} + \frac{\partial f}{\partial z} \cdot \vec{k}$, where \vec{i} , \vec{j} , \vec{k} are the standard unit vectors in the directions of the x , y , and z coordinates, respectively. With this notation, Eq. (421.10) can be written in terms of calculus so that

$$\vec{E} = -\nabla\phi .$$

The minus sign occurs because the electric field has a direction opposite to the direction of increasing potential. Equipotential lines are lines connecting points of the same electrical potential. All electric field lines cross all equipotential lines perpendicularly.

Experimental setup

Electrolytic tank

Low-voltage power supply

Multimeter LD analog 20

Pairs of cables 100 cm, red/blue (2 pts.)

Probe

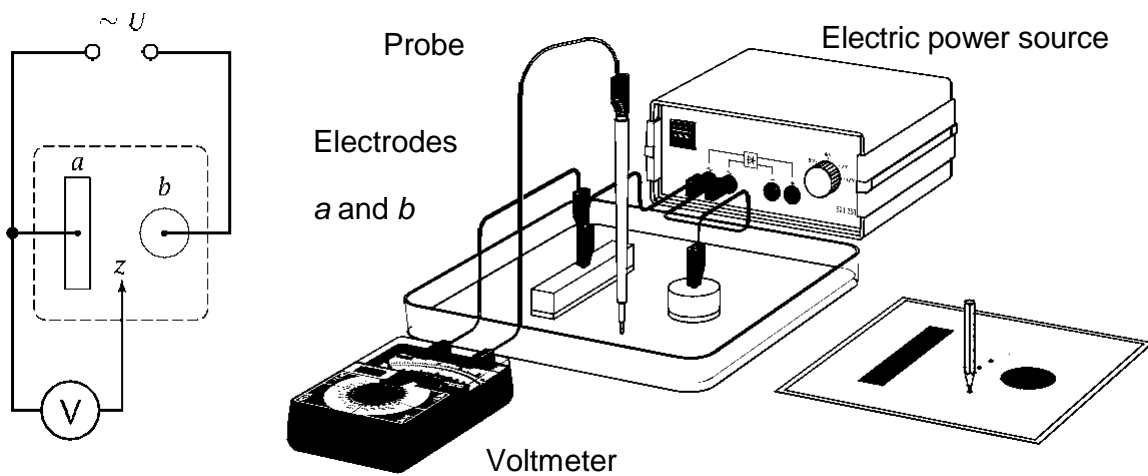

Figure 421.1. Experimental setup

Algorithm of measurements

1. Place one pair of electrodes **a** and **b** (as specified by the teacher) in the tank. Assemble the circuit as shown in Fig. 421.1. Use the AC output of the power source, not the DC! Set the limits of measurement 10 V in the AC mode on the voltmeter.

2. Take a sheet of graph paper and mark on it the position of the electrodes under study.

3. Pour a thin layer (3...5 mm) of distilled water into the tank.

4. Turn on the AC power supply. Turn on power only after a teacher/engineer checks the circuit.

5. Move the probe around electrode **a** until you find a point with a potential of 1 V. Mark this point on a graph paper and repeat this procedure several times until you can draw a 1 V equipotential line. Do not be afraid to go around the corner and behind the electrodes to measure potential and find points. Connect the points with a solid line.

6. Repeat step 5 for the 2, 3, 4, 5, 6, 7, 8, and 9 volt equipotential lines.

7. Draw the dotted lines perpendicular to the equipotential lines and indicate the direction of the electric field lines.

8. Ask your teacher to designate the points on your plot, where you should calculate the magnitude of the electric field. Label them $A, B, C...$

9. Calculate the electric field at point A by moving a small distance (less than 0.5 cm) to the left along the electric field line and a small distance to the right along the electric field line. Write down the electric potential at each of these points and find the potential difference, $\Delta\varphi$. Measure the distance between the two points, Δr . Calculate the electric field using Eq. (421.5). Repeat for each of the other points $B, C...$

10. Turn off the power and the voltmeter, pour out the water after completing the experiment.

Questions

1. What is an electric charge? What is an electric field? Describe their properties.

2. Coulomb's law. What is the unit of charge?

3. How is the electric field measured (in particular, the field of a point charge)?

4. What is an electric field line of force? What does the electric field have to do with moving charge (in the absence of other forces)? Can these lines intersect?

5. Direction of electric field lines for positive and negative charges. The principle of superposition of the fields.

6. Dependence of work during the movement of a charge in an electrostatic field on the potential difference at the initial and final points of the trajectory.

7. What is the potential of an electric field? How it is related to the potential energy of a charge in the field?

8. Equipotential surfaces. How are they oriented with respect to the lines of force? What equation relates the electric field and potential?

9. Electric dipole. What is the electric moment of a dipole? Sketch the dipole field.

10. Electrocardiography. Einthoven's triangle. Dipolar field of the heart. Analysis of electrocardiograms.

11. Gauss' law. Concepts of intensity vector flux, normal vector, solid angle.

12. The flux of the intensity vector in cases where a charge is inside/outside a closed surface.

13. Common features in the law of gravity and the law of electrostatic interaction.

451. Ohm's law in an alternating-current circuit and the determination of inductance and capacity

Objective

Verifying of Ohm's law in general.

Tasks

Determination of inductance.

Determination of capacity.

Experimental setup

The generator of harmonic oscillations “Г3-118” is connected to the terminal labelled “~V” in all circuits (Fig. 451.1). The generated frequency is derived as $f = (xy.z \times \text{multiplier}) \text{ Hz}$. In this figure, $f = 18.0 \times 10^2 = 1800 \text{ Hz} = 1.8 \text{ kHz}$. Set the generator output amplitude to its maximal value. The voltmeter “V” and the milliammeter “mA” should be set to the appropriate measurement mode (Fig. 451.2). The circuits can be modified by setting and removing jumpers into/from pins labelled **JP1–JP3**. A jumper (a piece of plastic-insulated conductor) closes a circuit when it is placed over the pins.

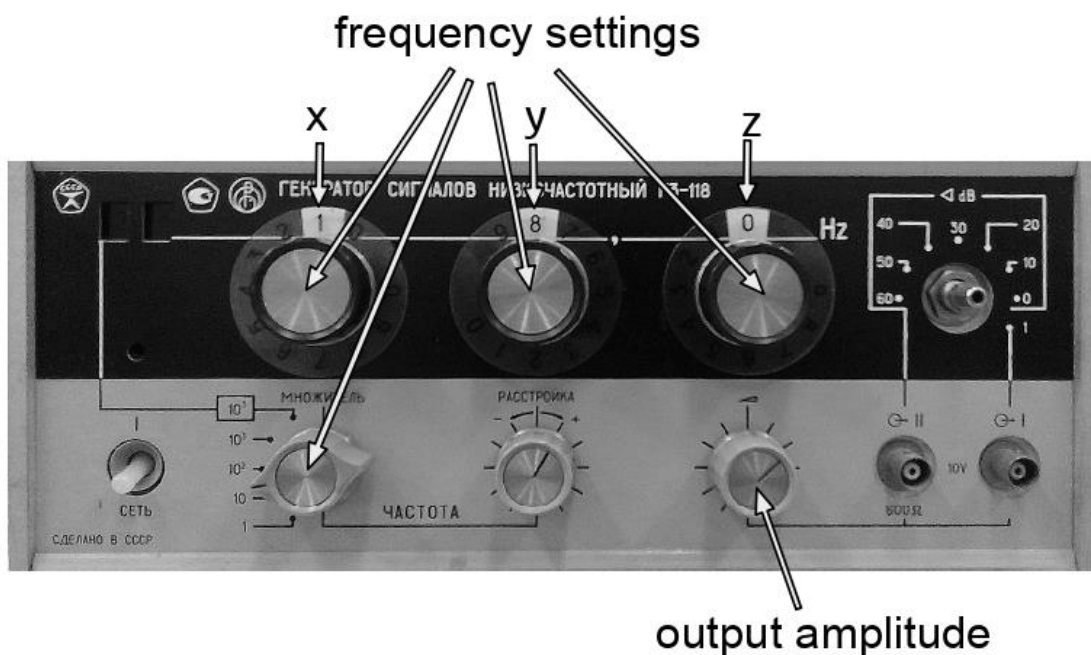

Figure 451.1. Generator

Algorithm of measurements

Task 1. Determination of inductance

1. Assemble the electric circuit according to Fig. 451.2 (left), where L is a coil with the inductance L to be measured and a known resistance of $R_0 = 10 \Omega$, and R is a constant resistance of 220Ω .

2. Measure and write down the values of the current $I_{i\,ef}$ (amperes) and voltage $U_{i\,ef}$ (volts) at five different frequencies of the generator ($f_i, i = 1 \dots 5$) chosen between 1 and 2 kHz in more or less equal steps. Let's rewrite the f_i values in the terms of angular frequencies $\omega_i = 2\pi f_i$.

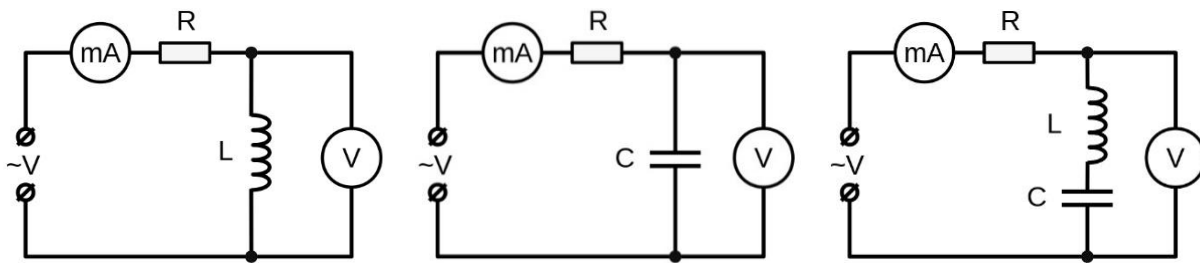

Figure 451.2. Circuits

3. For each value of $I_{i\,ef}$ and $U_{i\,ef}$ calculate the impedance of the coil using the equation $Z_{L\,i} = U_{i\,ef} / I_{i\,ef}$.

4. Calculate the inductance values using the equation $L_i = \frac{\sqrt{Z_{L\,i}^2 - R_0^2}}{\omega_i}$, and find the average value L_{av} and estimate the error (inaccuracy).

5. Find the phase shift angles (in degrees) between the current and voltage as follows: $\varphi_i = \arctan\left(\frac{\omega_i \cdot L_{av}}{R}\right)$.

Task 2. Determining the capacity

1. Assemble the electric circuit according to Fig. 451.2 (centre) with capacitor C of unknown capacity C .

2. Repeat step 2 from task 1. For each measurement $I_{i\,ef}$ and $U_{i\,ef}$, calculate the capacitor reactance as $X_{C\,i} = U_{i\,ef} / I_{i\,ef}$.

3. Calculate the capacity of the capacitor using the equation $C_i = \frac{1}{\omega_i \cdot X_{C\,i}}$, find the average of C_{av} and estimate the error/inaccuracy.

Task 3. General verifying of the Ohm's law

1. Assemble the electric circuit according to Fig. 451.2 (right).

2. Repeat step 2 from task 1. For each measurement $I_{i\,ef}$ and $U_{i\,ef}$, calculate the impedance of the series LR_0C -circuit as $Z_{LC\,i} = U_{i\,ef} / I_{i\,ef}$.

3. Using the L_{av} and C_{av} values obtained in tasks 1 and 2, find $Z'_{LC\,i}$ using the theoretical equation $Z'_{LC\,i} = \sqrt{R_0^2 + (X_{L\,i} - X_{C\,i})^2}$, where $X_{L\,i} = \omega_i \cdot L_{av}$.

4. Compare the measured value $Z_{LC\,i}$ with the theoretical value $Z'_{LC\,i}$ obtained in steps 2 and 3 of this task, and confirm the Ohm's law for the AC current. In case of discrepancy, explain the possible reasons.

Questions

1. What is alternating current? Draw plots of $I(t)$ and $U(t)$. Write down a law of change in voltage and current.

2. Define the instantaneous value, amplitude value, effective (current) value of current/voltage. Establish a relationship between them. What does the expression: "AC power 1 VA" mean? Why is the thermal effect of AC and DC compared?

3. How are voltage and current related in the resistor (for alternating current circuit)?

4. What resistance in AC circuit is called active?

5. What is a capacitor? What determines its capacity (formula, unit)? Why can't direct current pass through a capacitor?

6. What is the relationship between the phases of the current passing through the capacitor and the voltage on its plates relate? What is the capacity?

7. What is an inductor? What determines its inductance (unit)? Why does a self-induction EMF appear in it when the current in the coil changes?

8. What is the inductance of the coil? How does the phase of the current passing through the inductor relate to the voltage on it? Why is the inductance of a coil called reactive?

9. What is the time dependence of the voltage across the inductor and the capacitor in an L - R - C series circuit, if the voltage across the resistor changes with time according to the law $U_R = U_{Rmax} \cdot \cos(\omega \cdot t)$?

10. How does the impedance of the L - R - C series circuit to alternating current depend on the frequency of the current and the circuit parameters L , C , and R ?

452. Electric oscillations in an L - R - C series circuit

Objective

Study of an L - R - C circuit.

Task

Determination of the logarithmic decrement and the Q -factor of an L - R - C circuit.

An L - R - C series circuit contains an inductor with inductance L , a resistor with resistance R , and a capacitor with capacity C (Fig. 452.1 (left)). A real circuit has energy losses, mainly thermal due to Joule (ohmic) heating in the resistor, coil, and connecting wires, which all have the total active resistance R . For this reason, free oscillations are damped in such circuits.

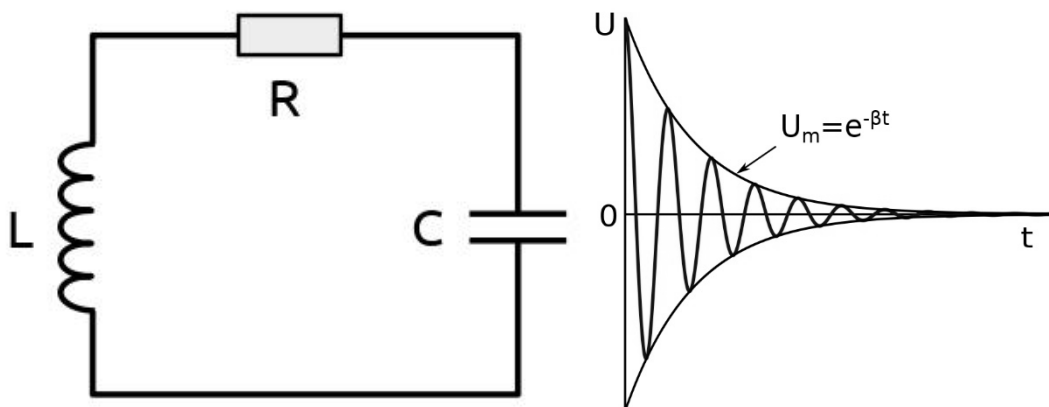

Figure 452.1. L - R - C series circuit and the dependence U_c vs. t in it

The Kirchhoff's loop rule for an L - R - C series circuit is

$$U_L + U_R + U_C = 0, \quad (452.1)$$

where $U_L = L \cdot \frac{d^2q}{dt^2}$, $U_R = R \cdot \frac{dq}{dt}$, and $U_C = \frac{1}{C} \cdot q$ are potential differences on the coil L , resistor R , and capacitor C ; the letter " d " means differential. Thus, we can derive differential equations for the free electric oscillations of the charge q and the voltage at the capacitor $U_c \equiv U$:

$$\frac{d^2q}{dt^2} + 2\beta \cdot \frac{dq}{dt} + \omega_0^2 \cdot q = 0 \text{ and } \frac{d^2U}{dt^2} + 2\beta \cdot \frac{dU}{dt} + \omega_0^2 \cdot U = 0 . \quad (452.2)$$

The value $\beta = R/2L$ is called the damping coefficient, and

$\omega_0 = 1/\sqrt{L \cdot C}$ is the natural frequency of the L - R - C series circuit.

The general solution of Eq. (452.2) is the equation of damping oscillations. For example, for the voltage U is written as (Fig. 452.1 (right))

$$U(t) = U_m \cdot e^{-\beta t} \cdot \cos(\omega t) , \quad (452.3)$$

where $\tau = 1/\beta$ is the relaxation time.

When $\beta^2 = \omega_0^2$, the system no longer oscillates, and the case of critical damping is reached.

In the case of underdamped circuit, $\beta^2 \ll \omega_0^2$, free decaying oscillations take place in the circuit. The voltage on the capacitor changes harmonically with time, but with a decreasing amplitude (Fig. 452.1 (right)). The frequency of the oscillations is

$$\omega = \sqrt{\omega_0^2 - \beta^2} . \quad (452.4)$$

In addition to the factor β , a logarithmic decrement λ is introduced in addition to the factor β to characterize the damping of oscillations. λ is defined as the natural (Napierian) logarithm of the ratio of two voltage amplitudes $U_0(t)$ and $U_0(t + T)$ of any two successive peaks:

$$\lambda = \ln \frac{U_0(t)}{U_0(t+T)} , \quad (452.5)$$

where T is the oscillation period. The value of λ can also be calculated as:

$$\lambda = \frac{1}{N} \ln \frac{U_0(t)}{U_0(t+N \cdot T)} , \lambda = \frac{1}{N_e} \text{ and } = \frac{\ln 2}{N_{0.5}} , \quad (452.6)$$

where $U_0(t)$ and $U_0(t + N \cdot T)$ are the voltage amplitudes separated by N oscillation periods, and N_e and $N_{0.5}$ are the number of oscillations after which the amplitude decreases by a factor of e ($e = 2.71828\dots$) or twice, respectively.

The quality of an L - R - C series circuit is characterized by the Q -factor, which is defined as

$$Q = \pi/\lambda . \quad (452.7)$$

The parameters β , τ , λ , and Q have the following relations:

$$\lambda = \pi/Q = \beta \cdot T = T/\tau . \quad (452.8)$$

In the underdamped mode, oscillations occur at a frequency close to the resonant frequency, i.e. $\omega \approx \omega_0 = 1/\sqrt{L \cdot C}$ or $T = 2\pi/\omega \approx 2\pi\sqrt{L \cdot C}$ and, hence:

$$Q \approx \frac{1}{R} \cdot \sqrt{\frac{L}{C}} . \quad (452.9)$$

The case of overdamped circuit: $\beta^2 \gg \omega_0^2$. In this mode, instead of oscillations, there is an aperiodic process of changing the charge and voltage on the capacitor and the current in the circuit, instead of oscillations. Fig. 452.2 shows the example plots of aperiodic voltage change $U(t)$ on the capacitor. If only the capacitor discharge process is occurring in the circuit, then the $U(t)$ curve has the shape presented in Fig. 452.2 (right). The minimum active resistance of the circuit, at which an aperiodic process is observed, is called the critical resistance R_{cr} . The value of R_{cr} can be found from the equation $\beta = \omega_0$:

$$R_{cr} = 2 \cdot \sqrt{L/C} . \quad (452.10)$$

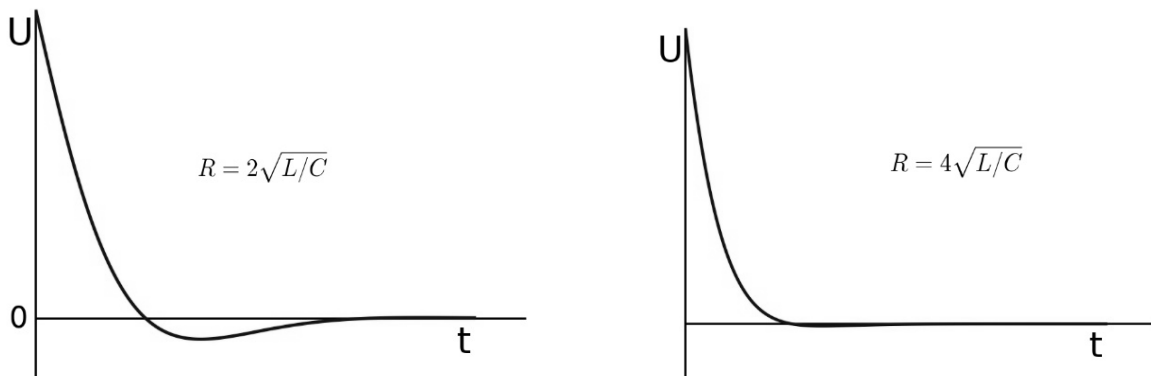

Figure 452.2. Example plots of U_c vs. t in the case of overdamped circuit

Experimental setup

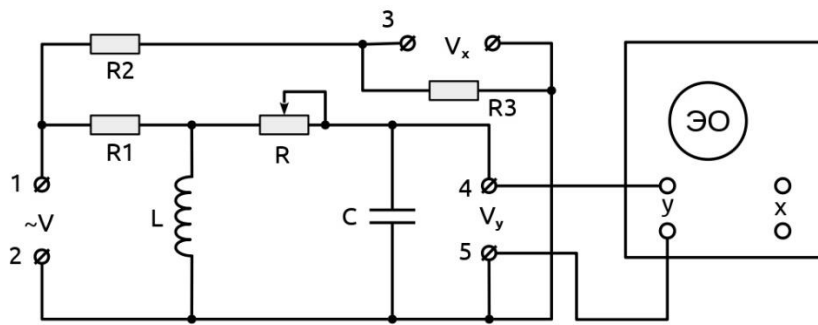

Figure 452.3. Circuit of the experimental setup

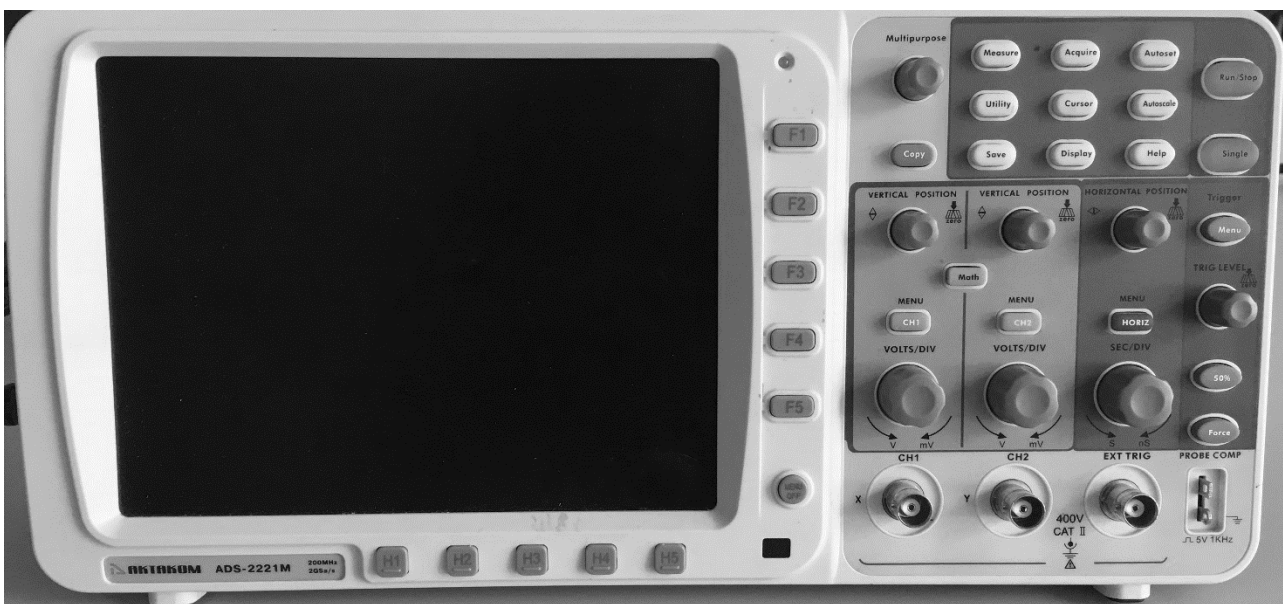

Figure 452.4. Oscilloscope

Algorithm of measurements

1. Connect the rectangular pulses generator to the contacts **1**, **2** (Fig. 452.3). Set the generator frequency to 300 Hz. Close the input pins of the cable connected to the “**CH2**” oscilloscope port and align the signal line with the middle horizontal line of the display using the “**vertical position** \blacklozenge ” knob (Fig. 452.4). Then reconnect the cable from “**CH2**” oscilloscope port to the pins **4** and **5**.

2. Set the resistor R to the minimum value. In case of problems, call the teacher/engineer, or check the following procedure: press the “**Autoset**” and “**Autoscale**” buttons on the oscilloscope. After that, turn

“**TRIG LEVEL**” knob on the top of the picture to obtain a stable image of the damped oscillations. Get a stable sine wave pattern containing several oscillations by adjusting the oscilloscope’s “Y” input gain (**VOLT/UNIT** selector on **CH2**) and sweep period (**SEC/DIV** selector).

3. To start measuring amplitudes, first press the green “**Run/Stop**” green button (picture will become static). Measure the amplitudes of two oscillations separated by k periods: a_n and a_{n+k} in **Volts** by using “**TRIG LEVEL**” knob (n and k are integers). “**TRIG LEVEL**” knob is a horizontal line gauge for measuring amplitudes. You need to match the “**TRIG LEVEL**” gauge with amplitude’s peak. After that, you will see the number of volts to measure in the lower right corner of the screen. For accurate measurement of the amplitude, the oscillation being measured should be placed on the central vertical gauge/scale using the horizontal position knob (“**horizontal position** $\triangleleft \triangleright$ ”).

Calculate λ and Q of the circuit by Eqs. 452.6 and 452.7. Repeat the measurement with different n and k (at least 3 sets) and find the average Q_{av} . Calculate the resistance R by Eq. 452.9, assuming that $L = 10$ mH and $C = 33$ nF. After all measurements of static picture, push again “**Run/Stop**” red button to set your picture being dynamic for further measurements with different resistances R .

4. Repeat step 2 for three values of R distributed over $3/4$ of the whole regulation range, starting with the smallest value.

5. Build the plots of dependencies Q vs. R and λ vs. R . Analyse the results.

Questions

1. What is alternating current? Draw plots of $I(t)$ and $U(t)$. Write down the law of change in voltage and current.

2. Define the instantaneous value, amplitude value, effective (current) value of current/voltage. Establish a relationship between them.

3. How are harmonic oscillations represented on a vector diagram?

4. How are cosine and sinusoidal oscillations depicted on a vector diagram? How are two synchronous oscillations depicted on a vector diagram?

5. How oscillations are added on a vector diagram?

6. Which electric circuit is called an $L-R-C$ series circuit? Where is the energy of the electromagnetic field stored in the $L-R-C$ series circuit?

7. Explain why harmonic undamped oscillations of charge and current occur in the $L-C$ series circuit? According to which law does the charge of the capacitor and the current in the inductor change with time?

8. How does the oscillation period in an $L-R-C$ series circuit depend on the magnitude of the electric capacitance and inductance of the elements?

9. Describe the phenomenon of resonance in an $L-R-C$ series circuit. How is the phenomenon of resonance used in radio engineering? Draw a resonance curve for two different resistance values.

10. Define the Q -value of the circuit (the formula for a serial and parallel $L-R-C$ circuit) and determine it from the resonance curve.

464. Semiconductor diodes

Objective

Studying the light-emitting diode, silicon diode, and Schottky diode.

Tasks

Studying the current-voltage characteristics of diodes.

Observation of rectified alternating current.

Experimental setup

Commutation in a circuit can be modified by setting or removing jumpers on the pins labelled **JP1–JP7**. A jumper (a piece of conductor in plastic insulation) closes a circuit when it is placed on the pins. When assembling, do not set jumpers on pins **JP4** and **JP5** at the same time!

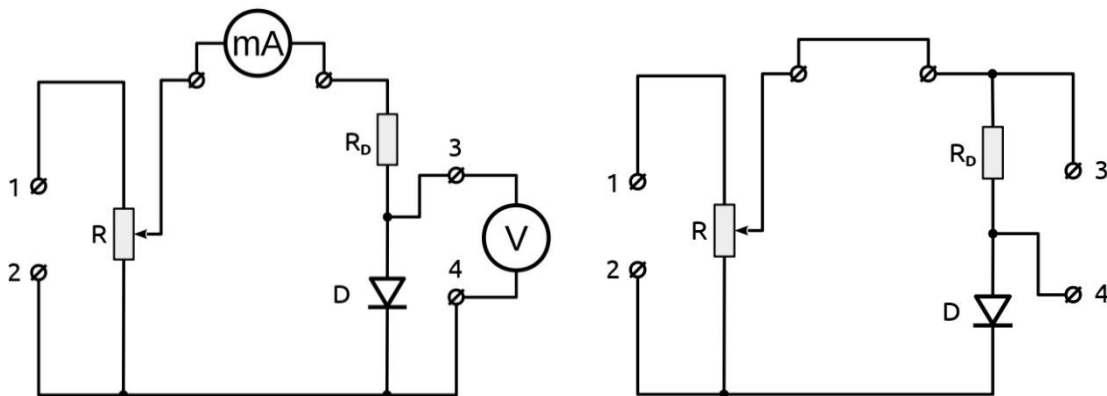

Figure 464.1. Circuits of the experimental setup

Algorithm of measurements

Task 1. Studying the current-voltage characteristics of diodes

1. Assemble the circuit according to Fig. 464.1 (left), where D stands for one of the following diodes: D1 is a light-emitting diode (LED), D2 is a silicon diode, and D3 is a Schottky diode. Turn on the DC power supply. If the power supply is regulated, set the output voltage to 4...5 V.

Connect the “+” lead of the power supply to the pin **1** of the circuit, and the “-” lead to the pin **2** (so that forward current passes through the diode).

2. Set the resistor R to maximum and measure the current I_{max} . By changing the resistance R , the currents and their corresponding voltages are measured in the current range from 0.5 mA to I_{max} . The step should be approximately $I_{max} / 6$. Fill in the table with values of voltage U and corresponding current I .

3. Repeat step 2 for other diodes.

4. Change the polarity of the voltage applied to pins **1** and **2** (reverse current passes through the diode). Voltage and current are measured by changing the voltage in 0.5 V increments in the voltage range from 0 to the maximum value. Every time when measuring the current, disconnect the voltmeter after reaching the required voltage.

5. Repeat step 4 for other diodes.

6. Build the plots I vs. U based on the data obtained for the three diodes in the same diagram. It is recommended to take milliampere (mA) as the forward current unit (positive part of the axis y), and microampere (μ A) as the reverse current unit (negative part of the axis y). Analyse the results.

Taks 2. Observation of rectified alternating current

1. Assemble the circuit according to Fig. 464.1 (right). Connect the harmonic oscillations source to pins **1**, **2**, and the oscilloscope to pins **3**, **4**.

2. Observe and draw a schematic of the rectified signal when diodes D2 and D3 are included in the circuit. Measure the amplitudes of the rectified signals for both diodes. Analyse the results.

Questions

1. Energy-band (zone) concept of solids.
2. What substances are called semiconductors? What kind of bond do atoms have in semiconductor crystals?
3. What is p -type semiconductor? Which valence atoms can be acceptor/donor impurities?

4. What charge carriers support an electric current in p - and in n -type semiconductors? How does the resistivity of semiconductors change:
a) when heated; b) under illumination?
5. What is a pn -junction?
6. Why, in the absence of an external electric field, electrons do not pass through the pn -junction from the n -semiconductor to the p -semiconductor?
7. Why does the pn -junction have one-way conductivity?
8. What are the advantages of semiconductor diodes over vacuum diodes?
9. What are the disadvantages of semiconductor diodes?
10. Why can not a semiconductor diode be used to rectify current at very low alternating voltages? Why is the application of semiconductor diodes limited at high voltages?
11. What is the current-voltage characteristic of a semiconductor diode? Breakdown of the pn -junction.

472. Temperature dependence of conductivity of electrolytes

Objective

Studying the conductivity of electrolytes.

Tasks

Studying the temperature dependence of the resistivity of NaCl aqueous solution.

The reciprocal of resistivity ρ is the electrical conductivity σ . The SI unit is the siemens per meter, S/m. The current density j (the SI unit is the ampere per square meter, A/m²) $j \equiv \frac{I}{A} = \sigma \cdot E$, where I is current, A is cross-section area, and E is electric field.

Compounds such as salts, acids, and bases that decompose into ions when dissolved or melted are called electrolytes. Decomposition of molecules into ions upon dissolving is called electrolytic dissociation. The degree of dissociation β indicates the fraction of the compound which is converted into ions. Strong electrolytes have β close to 1; weak electrolytes have $\beta \approx 0$. Dissociation in solutions occurs due to interaction between the electrolyte and polar solvent molecules (polar molecules are those that have a constant electric dipole moment; for example, water). Electrolytic dissociation is a reversible reaction (e.g. $\text{HCl} \leftrightarrow \text{H}^+ + \text{Cl}^-$). Ions produced in this reaction interact with solvent molecules. They form hydrates of constant or variable composition, such as H_3O^+ (hydronium ion).

Charge carriers in electrolytes are cations and anions (positive and negative ions, respectively). The conductivity of an electrolyte containing two types of ions is defined as

$$\sigma = \beta \cdot (n_+ \cdot q_+ \cdot b_+ + n_- \cdot q_- \cdot b_-), \quad (472.1)$$

where “+” means cation, “-” means anion, n is the number of ions per unit volume (concentration), q is the charge, and b is the mobility of charge. The SI unit for mobility is m²/(V·s). $b = v/E$, v is the charge drift speed.

The resistance of an electrolyte decreases with increasing temperature, since heating increases the dissociation degree and the ion mobility. The temperature dependence of an electrolyte resistance can be expressed by the following equation:

$$R = R_0[1 - \alpha(T - T_0)], \quad (472.2)$$

where R_0 is the resistance at the temperature T_0 , R is the resistance at the temperature T , and α is the temperature coefficient of resistance (which can be assumed to be constant over a narrow temperature range).

Experimental setup

In this work, the temperature dependence of the resistance R of an aqueous solution of NaCl is studied. The solution is poured into a glass tube with two electrodes and a thermometer. Heating is carried out by a wire wound on tubes and connected to the power source. (The alternating current is used in this work because of the use of the DC will lead to electrolysis processes, polarization of electrodes, a change in the chemical composition of the solution, the appearance of inhomogeneity in the liquid. The measured resistance in this case will differ from the true value.)

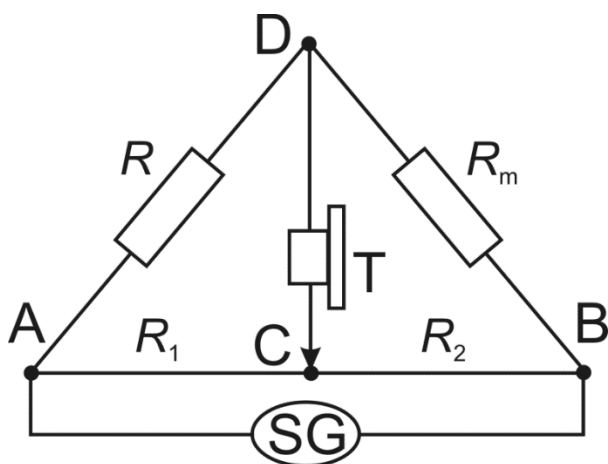

Figure 472.1. Circuit of setup

The resistance is measured using a Wheatstone bridge and alternating current (Fig. 472.1); here AB is the sliding wire (rheochord) with

the resistance of the legs R_1 and R_2 proportional to their lengths AC l_1 and CB l_2 (similar to what you can find in lab 413). Point C is the rheochord's slider, R_m is the resistance magazine. One diagonal of the bridge contains a sound generator SG. Telephone T is connected to another diagonal and works as a balance indicator in the bridge.

The balance is achieved when contact C is in such a position that the sound coming from the phone is the weakest (ideally it disappears). To define this point as accurate as possible, the resistance R_m in the magazine should be set so that the balance occurs when C is approximately in the middle of the wire. The determined resistance R is equal to

$$R = R_m \frac{R_1}{R_2} = R_m \frac{l_1}{l_2}. \quad (472.3)$$

Algorithm of measurements

1. If necessary, assemble the circuit according to Fig. 472.1. Turn on the sound generator SG with a quick button press. Find the balance: choose appropriate R_m in the magazine so that the sound disappears when the slider C is not too close to the terminals of the wire. Write down the resistance R_m and the room temperature T . Measure the bridge legs l_1 and l_2 and find the resistance of the solution R_x using Eq. (472.3).

2. Connect the other tubes and repeat the procedure in step 1. The task may be changed by the teacher.

3. Turn on the heater and measure the resistances of the electrolytes in each tube in 5–10° increments until the temperature achieves 90°C.

4. Turn off the heater. Repeat the measurements in steps 1–2 upon cooling until the temperature drops to ~30°C.

5. Build the plots R vs. T based on your experimental data.

6. Divide the measuring temperature range (20–90°) into 6–10 equal intervals ΔT_i . For each of these intervals, define the initial and final resistances R_{0i} and R_i and calculate the coefficient α_i using the equation

$$\alpha_i = \frac{R_{0i} - R_i}{R_{0i} (T_i - T_{0i})}$$

7. Build the plot α vs. T .

8. Analyse the results.

Questions

1. Why does water become a conductor when salts, acids or alkalis are dissolved in it?

2. What is electrolytic dissociation? Dissociation coefficient.

3. What is electrolysis?

4. What are the 1st and 2nd Faraday's laws of electrolysis.

5. Write Faraday's laws in mathematical form. What are the quantities and units included in this law?

6. What is called the electrochemical equivalent of a substance?

7. How to determine the charge of an electron?

8. Write the temperature dependence of the electrolyte resistivity.

What is the name of α ? Plot R vs. T .

9. How is electrolysis used in medicine? How is electrophoresis performed? Benefits of therapeutic electrophoresis.

10. Tell about the application of electrophoresis in biochemistry and molecular biology.

11. Measurement of conductor resistance with a Wheatstone bridge. Justify the application of the AC in the experiment.

Part 5. OPTICS

514. Centred optical systems

Objective

Studying the image formation in centred optical systems (COS).

Tasks

Studying the methods of measuring the focal lengths of converging and diverging lenses.

Observation of the dependence of the image on the position of the object in relation to the focus of the lens.

Geometrical optics

Geometrical optics is a branch of optics where light propagation is described by trajectories called rays. Light rays can be thought as geometrical lines that start at sources, pass through media, and end at detectors; they can be roughly defined as the path along which light energy travels. For a ray passing through a number of pieces of homogeneous media separated by refracting surfaces and possibly undergoing reflections as well, the ray path can also be determined in terms of the laws of reflection and refraction. Snell's law of refraction states that the sine of the angle between the normal and the incident ray bears a constant ratio to the sine of the angle between the normal and the refracted ray; with all three directions being coplanar. Behaviour of light rays (strictly speaking, paraxial rays) passing through a thin converging lens can be described by three main rules: (1) a ray parallel to the optical axis passes through the focus after the lens; (2) a ray passing through the focus becomes parallel to the axis; (3) a ray passing through the centre of the lens does not undergo refraction and remains straight.

Experimental setup

An optical bench.

Incandescent lamp in a case and power supply.

Aspherical condenser with diaphragm holder.

Semi-transparent screen.

Converging lenses with different focal lengths ($f = 50, 100, 150, 200,$ and 300 mm).

Diverging lens with the focal length of -100 mm.

Two transparent glasses with a drawing for studying image formation.

Measuring gauge (2 m).

Task 1. Determining the focal length of a converging thin lens

If the distance between an object and a lens ($-a_1$) is changed, then the image is formed at different distances a_2 from the lens according to the equation

$$\frac{1}{-a_1} + \frac{1}{a_2} = \frac{1}{f_2}, \quad (514.1)$$

where the focal length f_2 (or $-f_1$) of the lens can be found from the plot of $1/a_2$ vs. $1/a_1$ as the reciprocal of the segment cut off from the vertical axis.

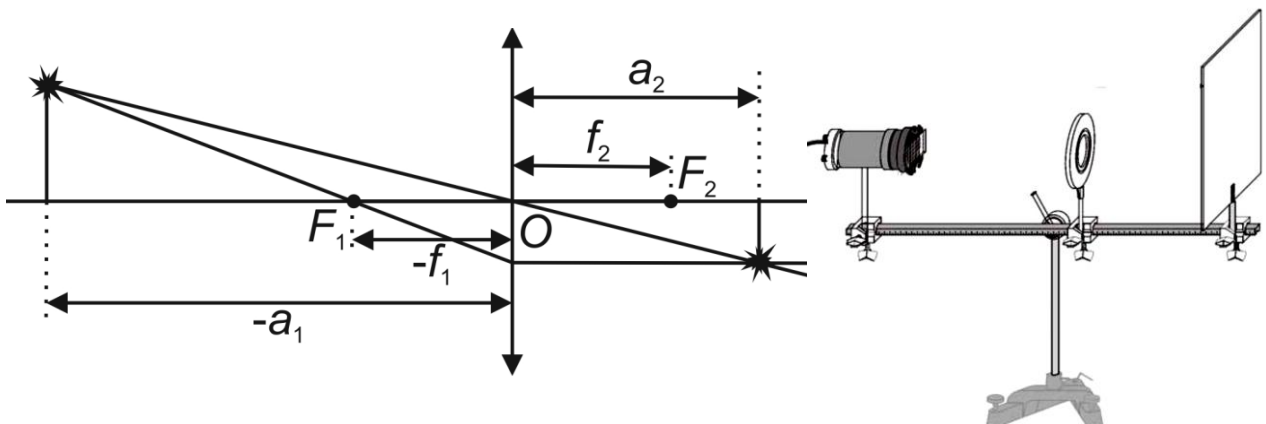

Figure 514.1. Ray diagram in a thin lens (left) and experimental setup for determining the focal length of a converging lens (right)

Algorithm of measurements

Task 1.

1. Install the lamp, converging lens, and screen on the optical bench (Fig. 514.1).
2. Insert the arrow-shaped diaphragm into the condenser holder.
3. Turn on the lamp.
4. Move the screen to the end of the bench.
5. By moving the lens between the screen and the object (diaphragm), get a well-defined (clear) image of the arrow on the screen.
6. Measure the distances $(-a_1)$ and a_2 (both numbers are positive).
7. Reduce the distance between the object and the screen by 3–4 cm and again find the distances $(-a_1)$ and a_2 that provide a clear image.
8. Repeat this 5 times.
9. Build a plot $1/a_2$ vs. $1/a_1$ and determine the focal length. Analyse the results.

Task 2. Determining the focal length of converging lenses by the Bessel's method

If the object and the image are separated by a distance greater than $4f$, then two positions of the lens can be found, one of which gives a magnified, and the other yields a decreased image (Fig. 514.2 (left)). The distance between the screen and the object in this experiment remains constant.

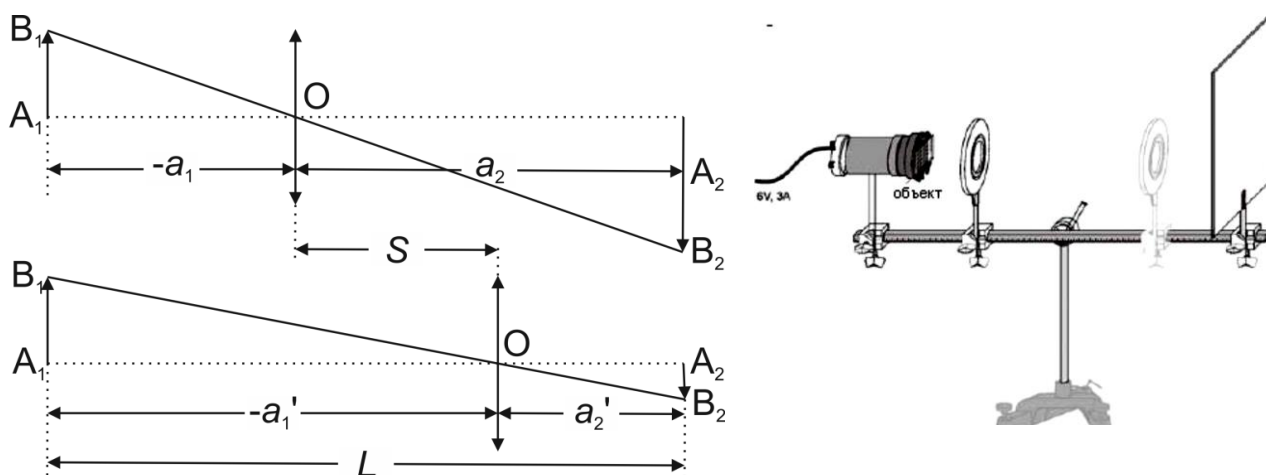

Figure 514.2. Ray diagram (left) and experimental setup (right) for determining the focal length of a converging thin lens by the Bessel's method

Let us introduce the values $S = (-a_1') - (-a_1)$ and $L = (-a_1) + a_2$ (the meaning of L and S is clear from the sketch in Fig. 514.2). Allowing for Eq. (514.1), we can derive:

$$f = \frac{L^2 - S^2}{4L}. \quad (514.2)$$

Algorithm of measurements

1. Install the lamp with the aspheric condenser at one end of the bench. Insert the glass with a drawing into the diaphragm holder.
2. Install the semi-transparent screen about 50 cm away from the object.
3. Install the lens with $f = 100$ mm between the diaphragm and the screen (Fig. 514.2 (right)).
4. Move the holder with the lens toward the object (closer to the lamp) until a well-defined image appears on the screen, measure the distance a_2 between the lens and the screen.
5. Move the lens toward the screen until you get another clear image. Measure the distance a_2' , between the lens and the screen.

6. Determine $S = (-a'_1) - (-a_1) = a_2 - a'_2$, and calculate the focal length of the lens by Eq. (514.2).

7. Repeat steps 3-6 with $f = 150$ mm lens. Before starting the experiment move the screen so that $L > 4f$. Analyse the results.

Task 3. Determining the focal length of a converging lens by the auto-collimation

Auto-collimation method is based on the reversibility of light propagation. If an object is placed at the focus of a lens, then after the lens there will be a light ray parallel to the optical axis. A plane mirror placed beyond the lens reflects this ray so that the object's image will be observed near the object (Fig. 514.3). The distance d between the lens and the image will be equal to the focal length of the lens f .

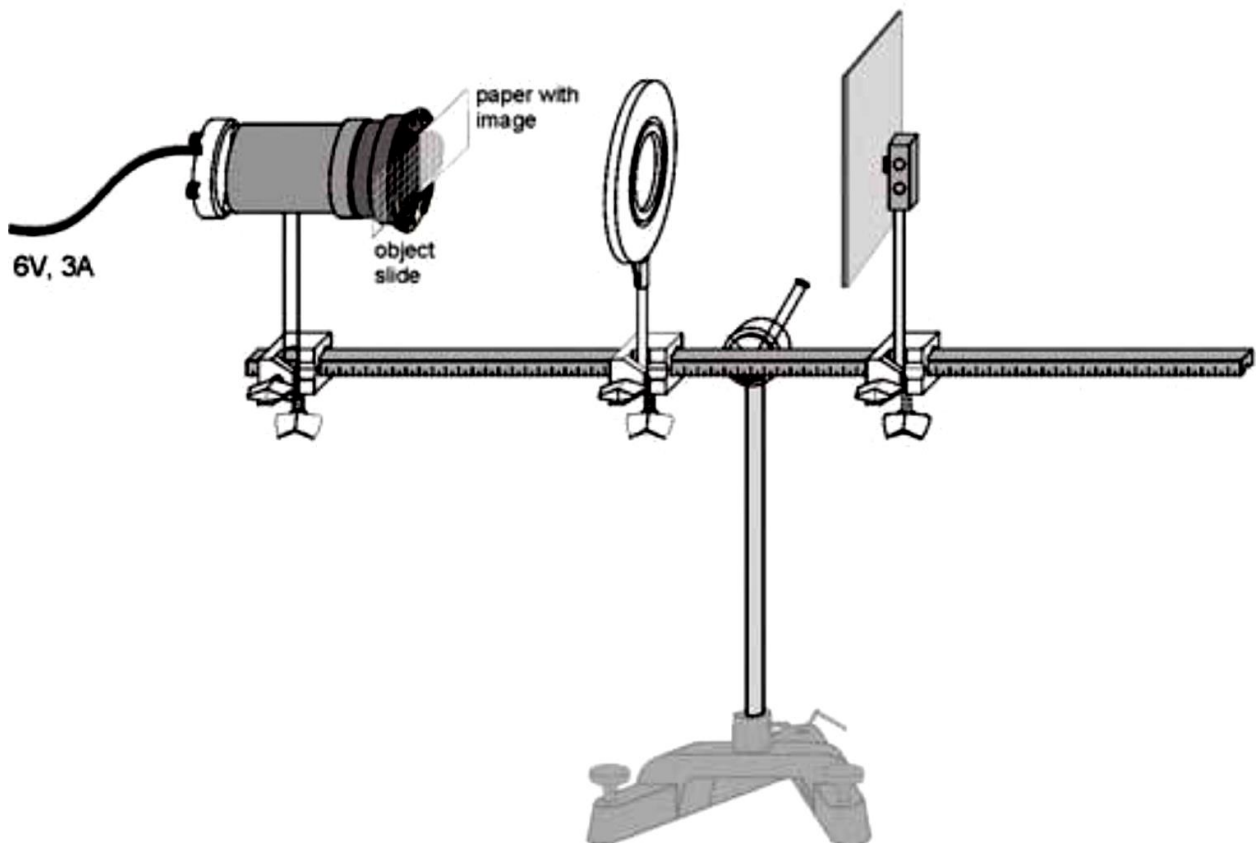

Figure 514.3. Experimental setup for determining the focal length by the auto-collimation

Algorithm of measurements

1. Install the lamp with the aspheric condenser on the optical bench as shown in Fig. 514.3.
2. Install the lens with $f = +150$ mm so that light passes through the lens parallel to the optical axis. The distance between the lens and the diaphragm holder should be approximately equal to the focal length of the lens.
3. Insert the glass with a drawing (object) and a sheet of white paper (screen for observing the object) into the diaphragm holder according to Fig. 514.3. Both the paper and the object should cover half of the condenser lens.
4. Install the mirror beyond the lens. The distance from the lens and the mirror may be less than the focal length.
5. Adjust the position of the lens until you get a well-defined image on the paper. It may happen that the position of the mirror and lens will have to be adjusted until the image is the same size as the object.
6. Measure the distance d between the lens and the object plane.
7. Repeat the experiment with other lenses. Analyse the results.

Task 4. Determining the focal length of the diverging lens

Focal length of a diverging lens is determined using an additional converging lens. If we place a diverging lens **2** on the path of the rays which are emitted from the source S and converge at point S_1 after being refracted in a converging lens **1**, so that the distance a_1 is less than the focal length $|f|$ of this diverging lens, then the image of the source S will move away from the lens **1**. Imagine that it moves to the point S_2 . Now S_1 is the object and S_2 is the corresponding image for the lens **2**. According to Eq. (514.1), the back focus of a diverging lens can be found as

$$f_2 = \frac{a_1 a_2}{a_1 - a_2}. \quad (514.3)$$

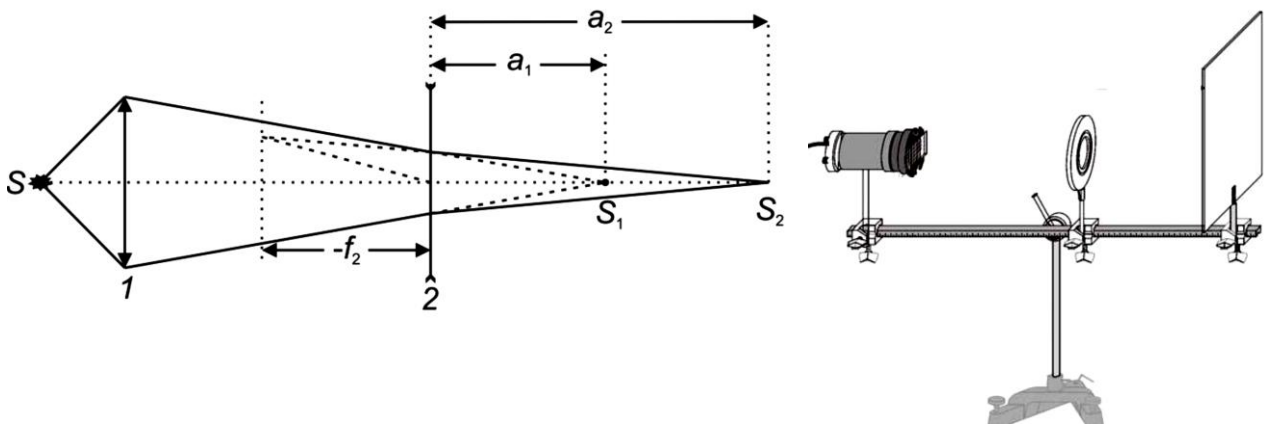

Figure 514.4. Ray diagram (left) and experimental setup (right) for determining the focal length of a diverging lens

Algorithm of measurements

1. Install the lamp, the converging lens with $f = 100$ mm, and the screen on the optical bench, as shown in Fig. 514.4.
2. Insert the glass with the drawing in the holder for the diaphragms.
3. Install the lens at a distance of ~ 30 cm from the object and obtain a well-defined reduced image of the drawing by moving the screen; remember this position of the screen (point S_1).
4. Install the studied diverging lens between the converging lens and the screen.
5. Find a new sharp image of the object by moving the screen (point S_2).
6. Having found the distances a_1 and a_2 (Fig. 514.4), calculate the focal length f of the diverging lens using the Eq. (514.3). Analyse the results.

Task 5. Determining the focal lengths of the converging and diverging lenses using parallel light rays

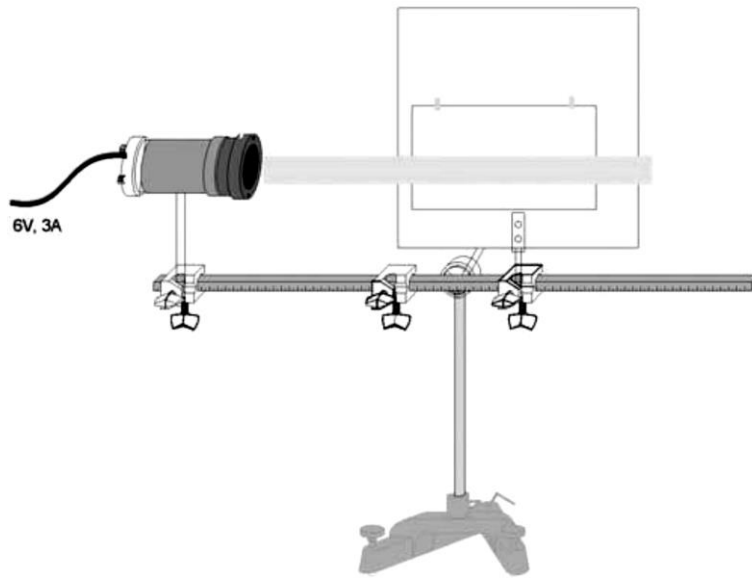

Figure 514.5. Initial experimental setup

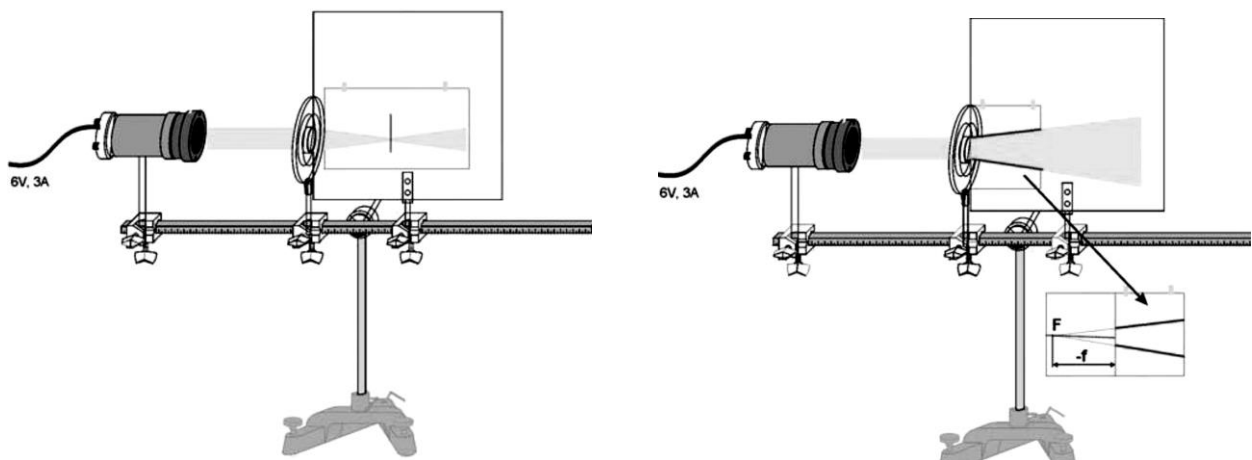

Figure 514.6. Experimental setup for determining the focal lengths of converging (left) and diverging (right) lenses using parallel rays

Algorithm of measurements

1. Install the lamp with the aspheric condenser and the semi-transparent screen on the optical bench (with the screen parallel to the bench as shown in Fig. 514.5). The lens is not needed yet.

2. Make a parallel light ray going along the optical axis. To do this, get a sharp image of the lamp filament (horizontal) at the most distant point (on a wall) by moving the lamp relative to the condenser.

3. Fix a sheet of white paper on the screen using Scotch tape. Make sure that the ray is a parallel ray.

4. Install the lens with $f = 100$ mm in the holder in front of the screen.

5. Mark the point of convergence of the refracted light (Fig. 514.6 (left)) and measure the focal length.

6. To find the focal length of the diverging lens, fold the paper twice and fix it on the screen so that the fold line coincides with the side of the screen near the lens (Fig. 514.6 (right)).

7. Mount the lens with $f = -100$ mm in the holder in front of the screen.

8. Draw the shape of the refracted ray on paper by drawing lines that bound the illuminated area.

9. Take the paper off, trace the lines back to the intersection point, and determine the focal length (Fig. 514.6 (right)). Analyse the results.

Questions

1. Converging and diverging lenses. How are they shown in diagrams?

2. Thin lens. Equation (deriving).

3. Optical power of a lens (equation, unit of measurement).

4. Focal length. What factors affect it?

5. Centered optical system: definition, characteristics.

6. Draw and describe images of an object formed by a thin converging lens in three cases: with an object between the lens and the focus, between focus and double focal length, beyond the double focal length.

7. Similarly, draw and describe images made by a diverging lens.

8. Optical system of the eye: dimensions, shape, composition.

9. Adaptation and accommodation. Optical power of the crystalline lens. The image formed on the retina.

10. Myopia and hyperopia, how they are corrected.

515. Telescope

Objective

Studying the telescope as a complex centred optical system.

Tasks

Determining the optical characteristics of telescope.

In the simplest case, a telescope and a microscope are optical systems consisting of two lenses. The first lens (objective lens O_1 in Figs. 515.1 and 515.2) is closer to the observed object AB and produces a real inverted image A_1B_1 of the object. This image serves as the object for the second lens (ocular O_2) that produces a virtual magnified A_2B_2 image positioned at the optimum viewing distance from the observer's eye.

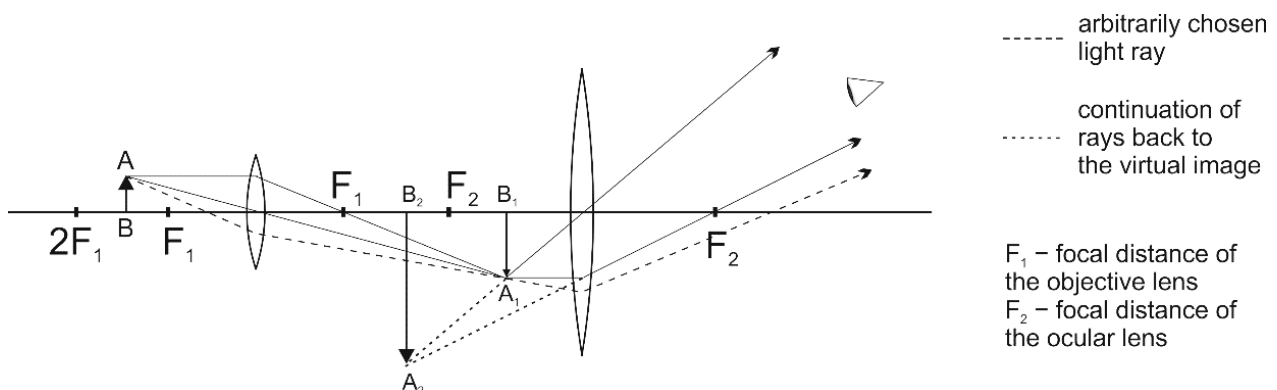

Figure 515.1. Ray diagram in a microscope

The objective lens of a microscope is designed to observe small objects at close quarters, so it has a short focal length. The object AB is placed slightly beyond the focus F_1 of the objective lens, and as a result its final image A_2B_2 observed through the ocular lens is greatly magnified (Fig. 515.1). Note that the image is reverted compared to the object.

Fig. 515.2 gives an example of a telescope consisting of a long-focus convex objective lens and a short-focus concave ocular lens (this scheme

was invented by Galileo Galilei). The objective lens of a telescope, which is used to observe objects at long distances (larger than twice the focal length of the objective lens) has a large focal length; in the absence of the ocular, it would produce a diminished image A_1B_1 close to the ocular O_2 . The ocular lens produces a new image of A_1B_1 , which is A_2B_2 in the sketch in Fig. 515.2 and appears closer to the observer O .

To characterise the gain of an optical system, a quantity called angle of view is used. It is the angle between the straight lines connecting the observer's eye to the edge points of the observed object. Notice that the angle at which the eye sees the final image $\angle A_2OB_2$ is much larger than the original angular size of the object (angle $\angle AOB$).

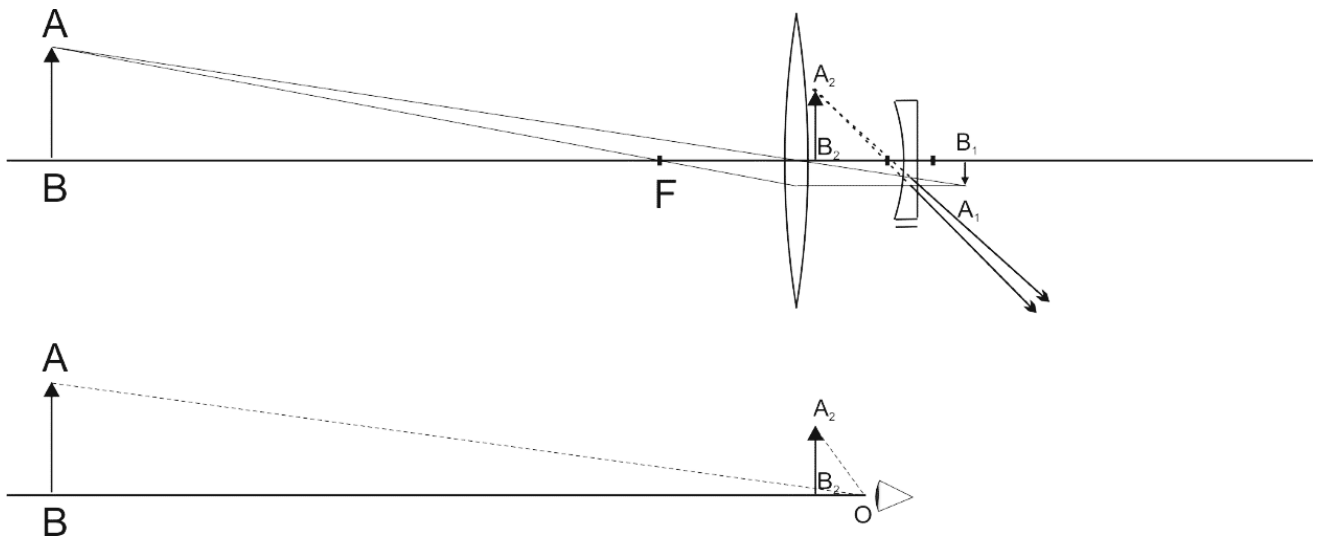

Figure 515.2. Ray diagram in a Galileo's telescope.

Task 1. Determining the magnification of a telescope

Angular magnification is the ratio of the tangent of an object angle viewed through a telescope to the tangent viewed with the naked eye.

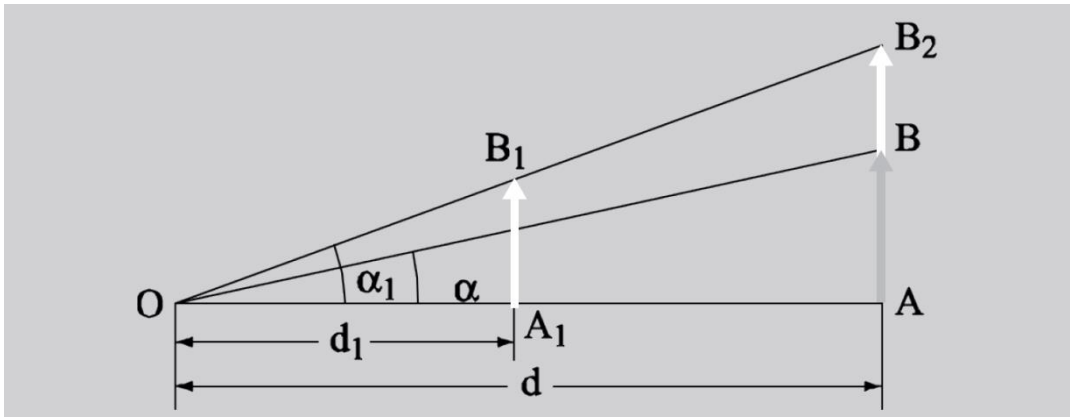

Figure 515.3. Magnification of a telescope

Let the object AB be at a distance d from the observer O ; A_1B_1 is the image of the object seen through a telescope and located at a distance d_1 from O ; α and α_1 are the corresponding viewing angles (Fig. 515.3).

Make a projection of the image A_1B_1 on the plane of the object; this operation gives AB_2 . This segment is at a distance d from the eye, but is still visible at an angle α_1 . The angular magnification is

$$\Gamma = \frac{\tan \alpha_1}{\tan \alpha} = \frac{AB_2}{AB}. \quad (515.1)$$

To determine the magnification of a telescope in practice, we will use the following procedure. Take a gauge with the distance l_0 between the marks. Observing the gauge through the telescope with one eye and directly with the other eye, combine the images so that the image inside the telescope overlaps with the gauge visible to the naked eye (Fig. 515.4).

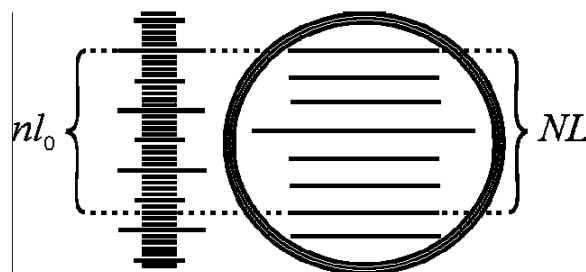

Figure 515.4. Determining the magnification of a telescope (example):

$$n = 27, N = 6, \Gamma = 27/6 = 4.5$$

Choose an integer n marks that are of the same size as N marks on the gauge image. Obviously, $n \cdot l_0 = N \cdot L$, where L is the length of the image of one segment between the marks. Then:

$$\Gamma = \frac{L}{l_0} = \frac{n}{N}. \quad (515.2)$$

Experimental setup

The telescope is shown in Fig. 515.5. Coarse adjustment of the telescope in the vertical plane is made after loosening screw **1**. Fine adjustment in the horizontal and vertical planes is made using screws **2** and **3**, respectively. A clear image of the crosshair is achieved by rotating the ocular ring **4**. A clear image of the object is obtained by rotating the screw **5** of the rack and pinion mechanism.

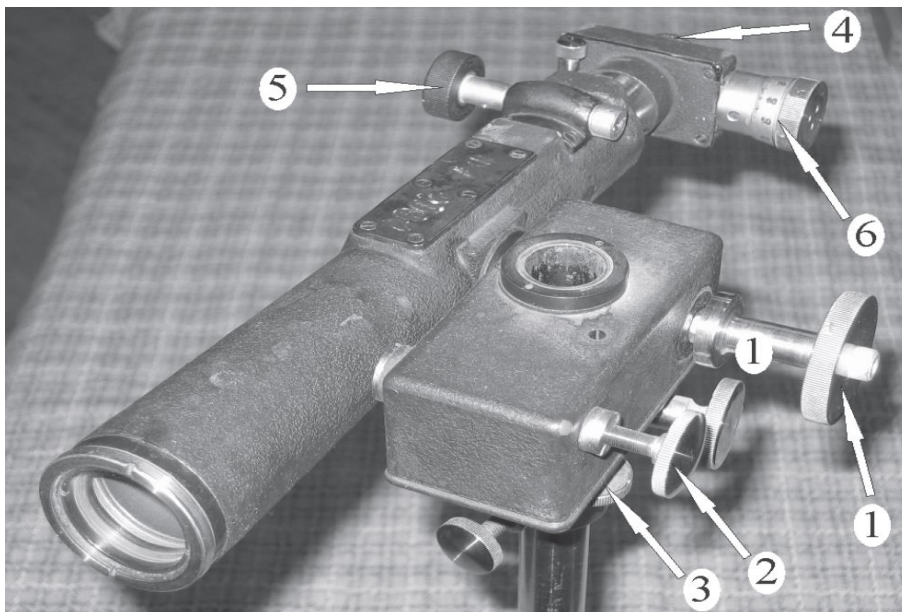

Figure 515.5. Telescope

Algorithm of measurements

1. Get a clear image of the gauge with marks (a ruler), when the gauge is at the distance of several meters from the telescope (see blackboard on the wall of the audience).

2. Look at the gauge through the telescope with one eye, and observe it with the other eye at the same time. Adjust the sight (scope) so that the image in the telescope overlaps with the real gauge.

3. Count n marks on the gauge and the corresponding number N of marks on the image of the gauge (Fig. 515.4).

4. Calculate the magnification factor Γ .

Task 2. Measuring the size of an object

The ocular of the telescope is equipped with a measuring crosshair of two thin perpendicular threads located near the focal plane of the ocular. The vertical thread can be moved in the field of view (FOV) using the micrometric knob **6**. One turn of the knob moves the crosshair in the tube by 1 mm. The wheel is divided into 100 parts; therefore, movement of the thread can be performed with an accuracy of 0.01 mm.

Algorithm of measurements

1. Determine the scale division value l' of the micrometer. To do this:

1.1. Put the gauge with a known scale interval at the same distance, where the measuring objects to measure will be placed at the next steps (for example, blackboard on the wall of the audience).

1.2. Target the telescope on the gauge and choose a segment with m marks.

1.3. By rotating the micrometric knob, superpose the crosshair with one end of the chosen segment; take the reading from the micrometer.

1.4. Superpose the movable crosshair with the other end of the segment and take the second reading. The difference n of the two readings gives the size of the object's image in the focal plane of the telescope.

1.5. Using the equation $n \cdot l' = m \cdot l$, calculate the scale division value of the micrometer: l' .

2. Determine the size of an object placed in the same plane as the gauge.

Task 3. Determining the field of view of the telescope

The part of the space (or plane), the image of which is visible in an optical system, is called the FOV of that system. For systems designed to observe distant objects (telescope, binoculars), the FOV is described by an angle $\phi = l/L$, where l is the distance between the most distant visible points of the plane containing the observed object, and L is the distance to the object (plane). As an angle, this value can be obtained from the equation

$$\phi = \frac{180^\circ}{\pi} \frac{l}{L} = 57.3^\circ \frac{l}{L}. \quad (515.3)$$

In binoculars, the FOV is typically 5-10°, while in the largest telescopes it does not exceed a few arcminutes.

Algorithm of measurements

1. Target the telescope on a gauge on the wall and take a clear image.
2. Define the part of the gauge l that is visible through the telescope.
3. Measure the distance L from the gauge to the objective lens of the telescope (do not touch the lens!).
4. Calculate the FOV using Eq. (515.3).

Questions

1. Converging and diverging lenses. How are they shown in diagrams?
2. Thin lens. Equation (deriving).
3. Optical power of a lens (equation, unit of measurement). Focal length. What factors affect it?
4. Centred optical system: definition, characteristics.
5. Draw and describe images of an object produced by a thin converging lens in three cases: with an object between the lens and the focus, between the focus and the double focal length, beyond the double focal length. Describe the obtained images.
6. Similarly, build and describe images made by a diverging lens.
7. Optical scheme of a microscope. Building an image in the system of an objective and an ocular.

8. Equation of the magnification of a microscope. Meaning and definition of the values used in the equation.

9. Resolution of a microscope. Equation for the resolution limit. How can this be improved?

10. Construction of the Kepler and Galileo telescopes. Draw the corresponding light ray diagrams.

517. Refractive index of liquids

Objective

Studying the method of measuring the refractive index of transparent liquids using a refractometer.

Tasks

Determine the concentration dependence of the refractive index of glycerol solutions.

Determine the refractive index of glycerol solution and its concentration.

A refractometer is a device for determining the refractive index of transparent liquids. The principle of operation of a refractometer is based on the phenomenon of total internal reflection that occurs at the interface between two media when a ray of light passes from an optically denser medium to an optically less dense one.

The main part a refractometer is a system of two rectangular prisms: illuminating $A_1B_1C_1$ and refracting ABC , made of glass with a high index of refraction (Fig. 517.1).

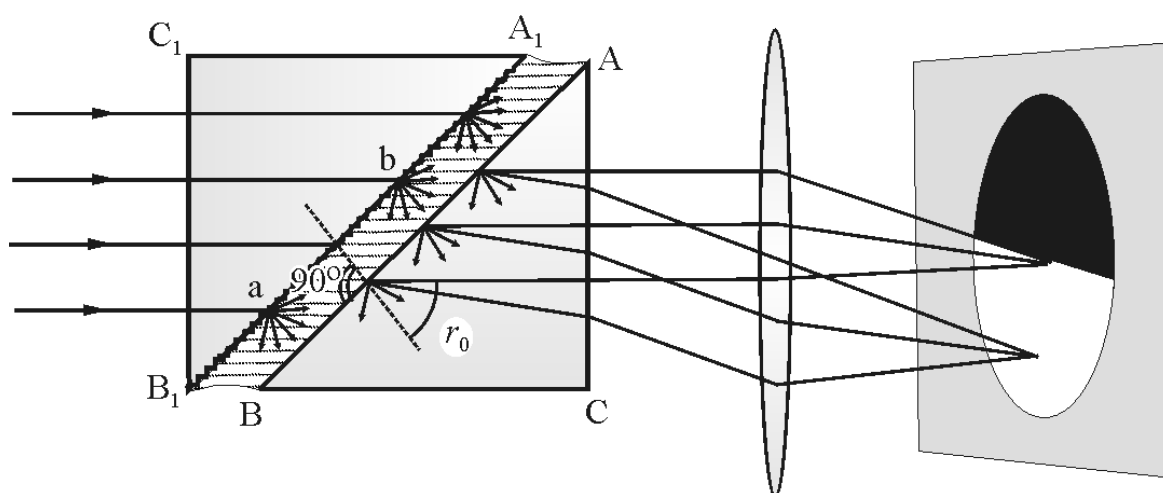

Figure 517.1. Refractometer

The illuminating prism has a matted A_1B_1 facet; the facet AB of the refractive prism is polished. Facets A_1B_1 and AB are parallel, and the thin gap between them is filled with a liquid studied.

The rays from the light source pass through the facet B_1C_1 of the illuminating prism and fall onto the matte facet A_1B_1 . Light is scattered and enters the liquid under study at all possible angles, as shown at points **a** and **b** in Fig. 517.1. In this case, the angles of incidence of the rays onto the interface AB between the liquid and glass have values from 0° to 90° .

For a ray sliding along the interface, the angle of incidence is 90° and, according to the Snell's law,

$$n_1 = n_2 \cdot \sin \theta_{\text{crit}},$$

where n_1 is the refractive index of the liquid, and n_2 is the refractive index of the prism ($n_1 < n_2$); θ_{crit} is the critical angle of total internal reflection.

When an ocular is placed in the path of the rays that have passed through the refracting prism, then the bottom part of its field of view (FOV) will be bright while the upper part will be dark. The boundary between light and shadow is defined by the ray corresponding to the critical angle.

When working in reflected light, the light falls onto the matted facet BC of the refracting prism. The light is scattered and incident onto the facet AB at all possible angles. Rays incident on the facet AB at angles smaller than the critical angle go into the liquid and then into the prism $A_1B_1C_1$. But rays with an angle of incidence greater than the critical angle experience a total internal reflection in prism ABC and leave the system through facet AC. Two areas will be observed in the FOV of the ocular: a bright upper part and a dark lower part.

When this phenomenon is observed with white light, the boundary between light and shadow is blurred and coloured due to dispersion. To remove colouring and to get a clear image, a compensator is used, consisting of two direct-vision prisms.

A double Amici prism consists of three triangular prisms made of different types of glass (Fig. 517.2). Two outer prisms are made

of crown glass with an index of refraction n_c , while the middle one is made of flint glass and has the index of refraction n_f ($n_f > n_c$). This assembly does not deflect yellow rays (centre in the spectral range) but deflects blue and violet rays to the base of the middle prism, and red and orange rays to its top.

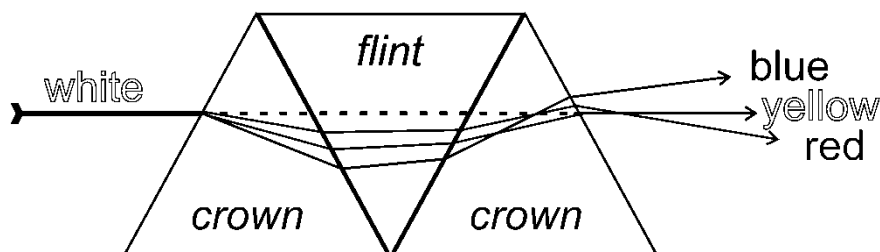

Figure 517.2. Ray diagram in a double Amici prism

If an Amici prism is placed in the path of the rays coming from the refracting prism so that its dispersion is the same in magnitude, but opposite in sign to the dispersion of the refracting prism, then the total dispersion will be equal to zero and the beam of coloured rays will unite into a white beam. In practice, it is convenient to use two direct-vision prisms, the total dispersion of which can be controlled by rotating them relative to each other.

The operation of a compensator can be clarified as follows. Take two Amici prisms, set them along the same optical axis, and look at a brightly illuminated object. You will see that it has blurry coloured boundaries. Rotate the prisms around the optical axis and achieve the disappearance of the rainbow colouring.

The refractometer consists of an upper and a bottom parts. The bottom (fixed) part is a refractive prism, and the upper part is the illuminating prism.

When measuring refractive index of liquids, put 2–3 drops of the liquid onto a clean polished facet of a refracting prism by a glass rod or a pipette (do it accurately, not touching the prism!). Put down the illuminating prism. Turn the knob to find the boundary between light

and shadow in the upper part of the ocular's FOV, and take the reading of the refractive index from the gauge.

Algorithm of measurements

1. Measure the refractive index of distilled water. Its tabular value is $n_w = 1.333$. Find the correction for the refractometer readings if it is different for pure water.

2. Measure the refractive indices of a series of solutions of glycerol with a known concentration and a solution of glycerol of unknown concentration. Apply the correction found in step 1.

3. After each measurement, carefully remove liquid from the facet of the prism with filter paper.

4. Build a calibration plot n vs. c , where c is the concentration of glycerol in water, and determine the unknown concentration from this plot.

Questions

1. Light: physical nature, ranges of wavelengths and frequencies.

2. Draw a schematic diagram of a light wave with its main parameters: wavelength, period, frequency... Specify units of measurement and relationships between these parameters.

3. Absolute and relative index of refraction. Definition, equations, and units of measure.

4. Laws of reflection and refraction of light. Draw a picture, indicate the angles.

5. Draw a picture with light transmission of the interface for a material with a lower refractive index.

6. Draw a picture with light transmission of the interface for a material with a higher refractive index. Total internal reflection.

7. Optical scheme of the refractometer. Application of its elements. What is a compensator used for?

8. Relationship between the refractive index and the solution concentration. Range of linear dependence.

9. Application of refractometry in pharmaceutical analysis. Purpose of the method, its advantages and disadvantages.

10. Two approaches to determining the concentration of a solution from the index of refraction.

521. Refractive index and dispersion of a prism

Objective

Studying the dependence of the refractive index on the light wavelength.

Tasks

Study the operation principle of a goniometer.

Determine refractive indices of a prism for different wavelengths.

Dispersion is the phenomenon of the dependence of the refractive index n (unitless) on the wavelength λ . By measuring n at different λ , one can obtain the dependence of n on λ . The n value of a transparent material in the visible light range decreases with increasing wavelength.

Its dependence is expressed as following: $n = a + \frac{b}{\lambda^2} + \frac{c}{\lambda^4}$. Here a , b , and c are constants for a given material which are found experimentally.

In many cases, this expression can be limited to the first two terms:

$$n = a + \frac{b}{\lambda^2} . \quad (521.1)$$

In this work, the method for finding the refractive index of glass by measuring the minimal deviation angle of a parallel monochromatic light ray passing through a prism is described.

Suppose that the rays fall onto one facet of a glass prism with a refractive index n ; and that the angle of incidence is α (Fig. 521.1). The angle between the facets of a refracting prism is denoted A .

The ray leaving the prism forms an angle β with the rear facet; the angle between this ray and the continuation of the incident ray is φ . The refraction angle depends on the angle of incidence. It can be proved that if the ray path in the prism is symmetric (that is, $\alpha = \beta$), then the angle φ has the smallest possible value. Let's denote it as φ_{\min} . The values of n , A , and φ_{\min} are related to each other by:

$$n = \frac{\sin\left(\frac{A + \varphi_{\min}}{2}\right)}{\sin\left(\frac{A}{2}\right)}. \quad (521.2)$$

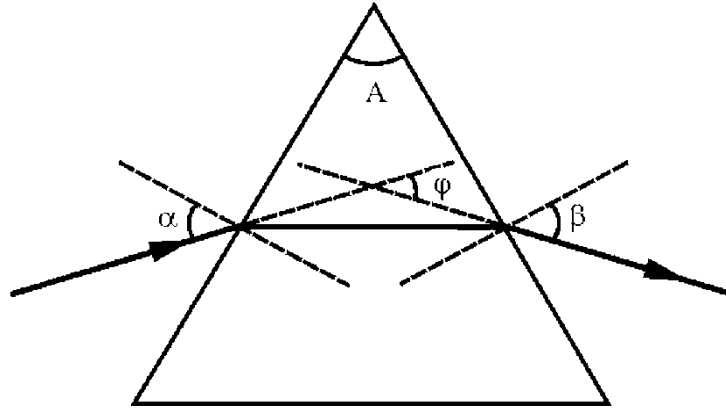

Figure 521.1. Ray diagram in the prism

Thus, finding the refractive index requires measuring the angles A and φ_{\min} . This measurement can be done out using a goniometer (a device for accurate measurement of angles).

Experimental setup

Goniometer (Fig. 521.2) consists of the following main units: tube **1** for observing refracted or reflected rays; collimator **2** forming a parallel light ray; table **3** for installing the object of study; measuring gauge for determining rotation angles of the observation tube (this part includes a limb **10**, an optical microscope **4**, and an optical micrometre). The observation tube is a “telescope” with a long focal length of the objective lens and a short-focus ocular. The ocular is equipped with a vertical thread used for selecting a certain spectral line.

For spectral studies, a prism is installed on the table **3** and illuminated with a parallel light ray formed by the collimator **2**. The latter is a tube fixed on the base of the setup. There is an objective lens at one end of the collimator and a slit at the other end, in the focal plane of the objective lens. The slit is illuminated by a mercury lamp, which

produces a discrete (line) spectrum (the spectrum of Hg is printed on the workplace and in the appendix of this book, see Fig. A1). Parallel rays going out of the collimator are refracted by the objective lens of the tube and produce an image of the slit in its focal plane. When the observation tube is focused to infinite, a clear image of the slit is seen through it.

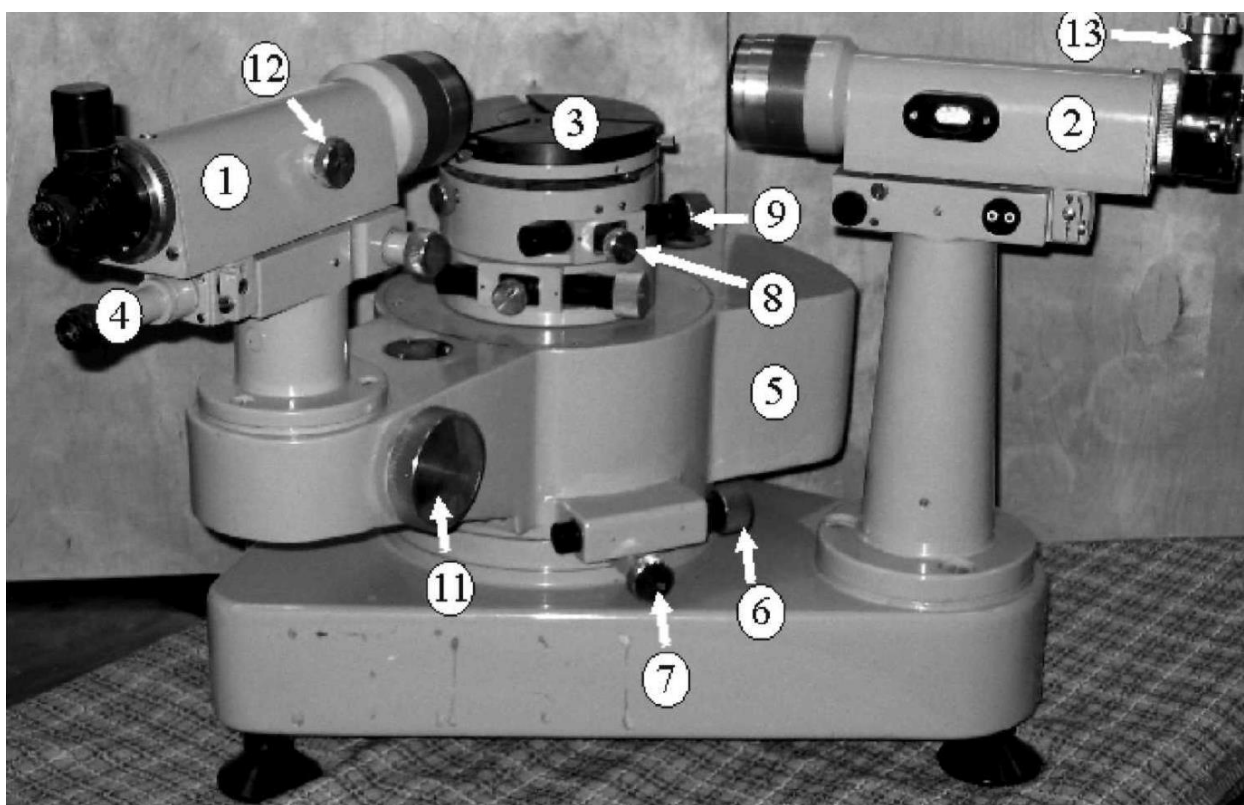

Figure 521.2. Goniometer (GS-5)

The observation tube **1** and microscope **4** are attached to the movable mounting **5**. If the screw **7** is loosened, the mounting can be rotated by hand. If the screw **7** is tightened, the mounting **5** can be precisely rotated through a small angle with the micrometre screw **6**. When adjusting the goniometer, the observation tube is rotated relative to the fixed table **3**. The table is fixed with the screw **8**. Precise rotation of the table is achieved with micrometre screw **9** when the screw **8** is tightened. During measurements, the table should be fixed, and the observation tube **1** should be rotated only.

To measure the rotation angle of the tube, the gauge consisting of the limb, the optical micrometre and microscope **4** are used to measure the rotation angle of the tube. The field of view (FOV) of the microscope is shown in Fig. 521.3.

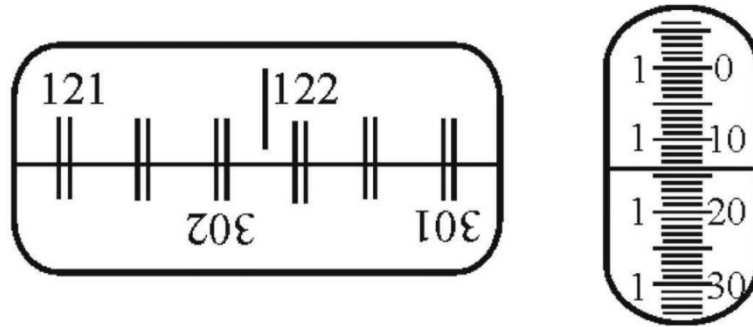

Figure 521.3. Field of view of the microscope

The left window shows diametrically opposed segments of the limb and the vertical index as seen through the ocular **4**. The scale interval of the limb is $20'$ (' means arcminute, '' means arcsecond). The limb is fixed to the solid base, so the reading from the limb changes when the observation tube is rotated.

The right window shows the image of the optical micrometre scale. The scale shift by 600 intervals corresponds to the shift of the upper limb marks relative to the lower scale by $10'$. In other words, the scale interval of the right gauge is $10'/600 = 1''$.

To read the limb, turn the screw **11** of the optical micrometre so that the marks of the upper and lower limb images in the left window coincide (Fig. 521.3).

The degree count is given by the nearest number to the left of the vertical index (121° in the example above).

The number of tens of arcminutes is equal to the number of intervals that fit in the space between the upper double mark, which was selected in the previous step (integer degree count), and the lower double mark, which differs from the top one by 180° . In our case, it is 301°

($121 + 180 = 301$), there are five intervals between these two marks, so the count of tens of arcminutes is $5 \times 10' = 50'$.

Integer arcminutes are counted on the left vertical scale in the right window; the right part of the same scale gives the number of arcseconds. As a result, the angle in Fig. 521.3 is equal to $121^\circ 51' 14''$.

Algorithm of measurements

Preparing the goniometer for measurements

1. Adjustment of the observation tube. The tube should be focused to infinite. To do this, look through the observation tube at some a distant object (e.g., at a building on the street) and obtain a fine image by rotating the screw **12**.

2. Focusing the collimator. Place the lamp in front of the collimator slit, and turn it on. Illuminate the slit and look at the image through the observation tube. Make the image of the slit clear by rotating the screw (the collimator screw is not shown in the figures, but it locates similarly to that of the screw **12** on the observation tube).

3. Choosing an appropriate slit width. Adjust the slit width by rotating screw **13** so that the emission lines in the spectra are narrow and fine, but at the same time bright enough. When decreasing the width of the slit, the lines first become narrowing at a constant brightness level, and then the line width becomes constant and their brightness decreases abruptly. You should find this threshold (so-called “normal slit width”) and continue measurements at this value.

Show the results of the above procedure to the teacher/engineer before proceeding.

Task 1. Determining the refractive angle of a prism

1. Install the prism on the table **3** so that its edge is vertical, and the light ray from the collimator falls on both sides and on the edge of the refraction angle (Fig. 521.4). Fix the table with screw **8**.

2. Loosen screw **7** and turn the optical tube along the ray reflected from one of the facet of the prism (position *I* in Fig. 521.4).

3. Rotate the tube slightly by hand to obtain the image of the collimator slit in reflected light. Focus this image using the screw **12**. Overlay the image of the slit with the vertical line in the ocular and read the angle.

4. Loosen screw **7** and turn the tube to find the image of the slit reflected from the other side of the prism (position *II* in Fig. 521.4). Tighten up screw **7**, overlay the image of the slit with the vertical line and read the angle. The difference between the angles measured in steps 3 and 4 is the angle *B*, which is twice the angle of refraction *A*.

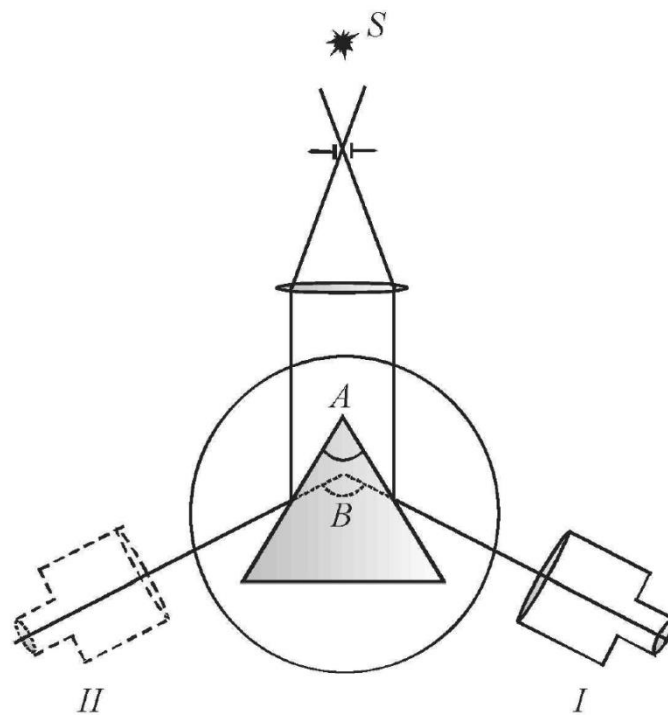

Figure 521.4. Experimental setup

Task 2. Determining the refractive index and dispersion of the material of the prism

1. Take off the prism, turn the observation tube to see the image of the collimator slit, superpose it with the vertical thread, and read the angle α_0 (it is the direction of the incident ray).

2. Install the prism on the table so that the ray from the collimator passes through the prism (Fig. 521.5). Set a slightly larger angle of incidence; rotate the tube and capture the spectrum in the FOV.

3. Loosen the screw **8**. Rotate slowly the table by hand (reducing the angle of incidence) and observe how the spectrum moves in the observation tube. First it will move in one direction, and then it will shift to the other side, although the rotation direction of the prism (table) will remain the same. The moment of change the direction of movement corresponds to the prism position with the minimum deviation (refraction) angle of the ray.

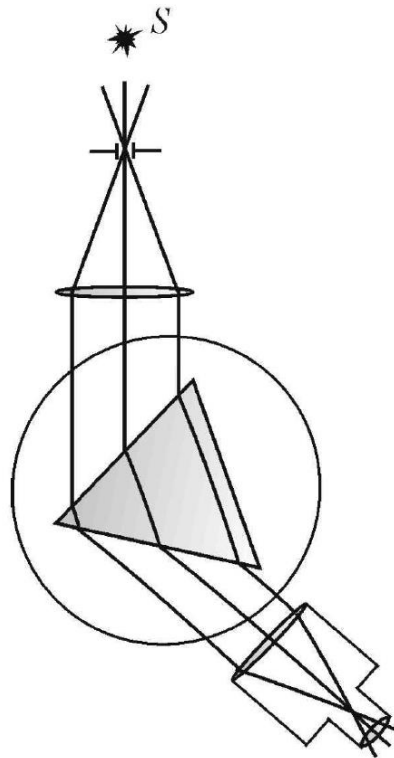

Figure 521.5. Experimental setup

4. Superpose the vertical thread with the spectral line, for which the refractive index of the material of the prism (glass) has to be found. Find the table position α corresponding to the minimum deviation angle φ_{\min} and calculate the latter as $\varphi_{\min} = \alpha - \alpha_0$. Calculate the refractive index using Eq. (521.2) for the wavelength corresponding to the chosen spectral line.

5. Repeat these measurements for all observed spectral lines of mercury and calculate their corresponding refractive indices.

6. Build the plot n vs. λ . Define its slope (actually the dispersion of the glass) in the long and short wavelength parts of the spectrum.

7. Check the Cauchy Eq. (521.2) in the investigated wavelength range. To do this, use the linearisation method. Choose the variables so that the function under study becomes linear. In our case, if new variables $Y = n$ and $X = 1/\lambda^2$ are introduced, then the Eq. (521.2) is written as $Y = a + b \cdot X$. If the Cauchy equation is applicable, the $Y(X)$ plot will be a straight line with the slope b and crossing the vertical axis at the coordinate a .

Questions

1. Draw a schematic diagram of a light wave with its main parameters: wavelength, intensity, frequency... Specify units of measurement and the relationships between these parameters.

2. Different types of electromagnetic radiation. Briefly describe them and their applications.

3. Speed of electromagnetic waves in vacuum and in various media.

4. The phenomenon of dispersion. What causes dispersion?

5. Normal and anomalous dispersion. The dependence of the refractive index on the wavelength.

6. Optical spectra: atomic (lines), molecular (bands), continuous. Quantum-mechanical basis of line spectra of atoms.

7. Absorption and emission spectra – how are they produced and how do they look like? What types of spectra have been observed in this lab?

8. Qualitative and quantitative spectral analysis.

9. What is colour, how do people (animals) distinguish different colours?

10. Ray diagram in a prism. The minimum deviation angle.

11. Classical (electronic) theory of dispersion. Complex refractive index.

563. Grating spectrometer

Objective

Studying the diffraction grating.

Tasks

Study Fraunhofer diffraction.

Determine the wavelength of the spectral lines.

Creation of a reflection diffraction grating: a thin layer of a soft metal is deposited from metal vapour onto a glass plate in a vacuum. Then, grooves with a saw-shape profile are formed in this layer using a special diamond tool. Such a profile allows the maximum of light energy to be concentrated not in the zero-order spectrum, as in conventional diffraction gratings, but in a spectrum of any given order. The diffraction pattern produced by a grating is a combination of two patterns: diffraction from a single reflective element and interference from N reflective elements.

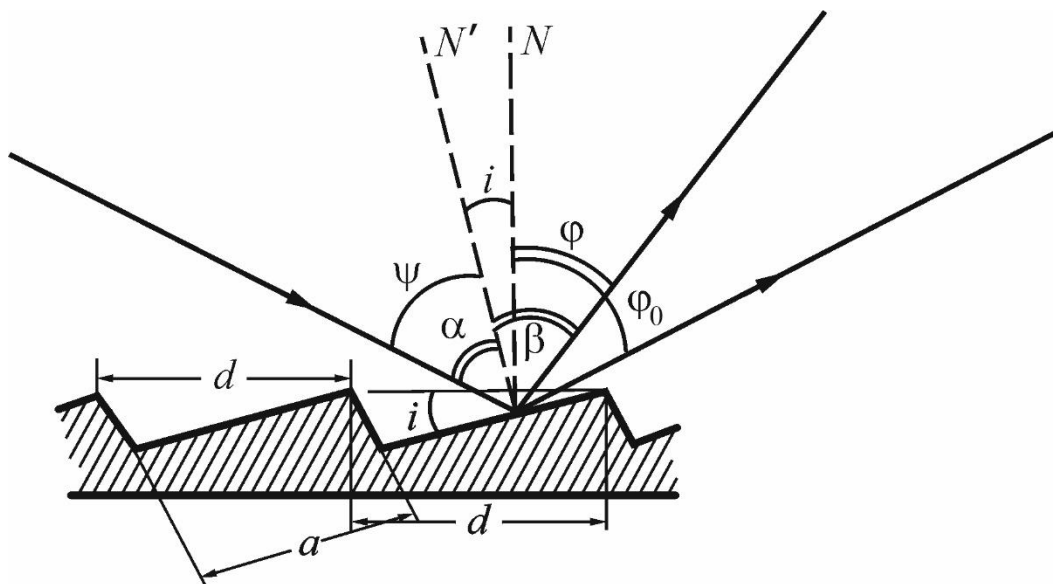

Figure 563.1. Ray diagram reflected from a diffraction grating

Let a plane wave be incident on the plane of the grating at a certain angle ψ . The diagram is shown in Fig. 563.1, where N is the normal

to the grating plane as a whole, N' is the normal to the reflecting elements, ψ is the angle of incidence and φ is the diffraction angle, i is the angle of the grating profile, α is the angle of incidence relative to a single mirror element, and β is the diffraction angle from a reflecting element, a is the width of the mirror element, and d is the grating period.

The angles are measured from the normal to the grating plane. The direction of reference clockwise from the normal is assumed to be positive (in our diagram, φ and φ_0 are positive, while ψ and i are negative). The orders of the spectra that appear clockwise relative to the zero order spectrum are also assumed to be positive. Obviously, the zero-order maximum is observed in the direction $\varphi_0 = |\psi|$.

The direction of the zero-order diffraction maximum of a single mirror element appears at the angle $\beta = -\alpha$. To attain the light energy concentration in the required order, it is necessary that the maximum of a mirror element, corresponding to its own reflection, coincides with the given maximum of the grating. This condition is fulfilled when both equations:

$$d(\sin\psi + \sin\varphi_n) = m\lambda_n, \quad (563.1)$$

$$\psi + \varphi_n = i \quad (563.2)$$

are true simultaneously.

These conditions are strictly fulfilled only for one value of the wavelength when i , d , φ , ψ , and m are fixed. However, the spectral energy distribution of a single reflecting element slowly decreases from the centre toward the edge, and, therefore, the energy will be concentrated for other wavelengths close to λ_n .

Experimental setup

The grating used in this setup has 600 grooves per 1 mm and $i = 12^\circ$; this allows the light to be concentrated in the first order spectrum, when the angle of incidence is close to 43° . The grating is installed on a goniometer (Fig. 563.2 (left)).

The goniometer consists of a fixed collimator tube; a slit is placed in the focal plane of the collimator objective lens **7**. The slit width is controlled by the screw **2**. The observation tube **3** is movable; by rotating it around the vertical axis, spectra of different orders can be observed. The diffraction grating is installed on the table **4** with a limb on it. The optical tool **5** allows measuring the rotation angle of the tube with an accuracy of $1''$ ($''$ means arcsecond).

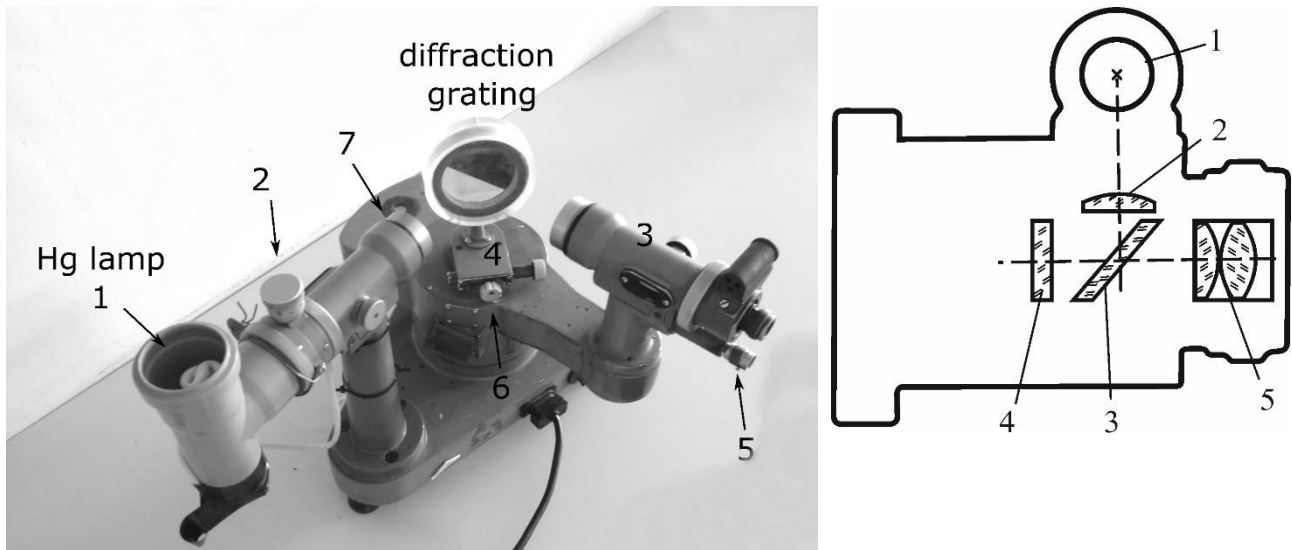

Figure 563.2. Setup (left) and the autocollimating Gauss ocular (right)

The observation tube is equipped with an autocollimating Gauss ocular (Fig. 563.2 (right)). The light from a lamp **1** passes through a matted plate **2**, is reflected by a parallel-sided plate **3** (a block that has been precision ground and lapped to a specific thickness), then passes through a plate **4** with a crosshair drawn on it (the plate **4** is near the focal plane of the ocular **5**), and finally exits the tube objective and falls onto the mirror surface of an object located on the goniometer table.

The tube is matched to the infinite distance if the crosshair and its image are both seen simultaneously through the ocular **5**. In this case, indeed, the planes of the crosshair and its image coincide, which means that both these planes coincide with the focal plane of the tube objective lens. The reflecting surface of the object should be strictly perpendicular to the optical axis of the tube.

Algorithm of measurements

1. Turn on the lamp and the backlight of the goniometer.

2. Adjust the observation tube to the infinite distance and find the direction of the grating plane. To do this, align the observation tube at an angle slightly greater than 90° relative to the collimator, loosen the clamping screw **6** (Fig. 563.2 (left)) and rotate the grating (table) until a light crosshair appears in the field of view. Then fix the grating with the clamping screw. Achieve a clear image of the light crosshair by adjusting the focus of the observation tube. Superpose the light crosshair with the crosshair in the ocular manually or using the micrometric thimble. Read γ_N from the limb gauge. This reading gives the direction of the normal relative to the grating plane. Since the limb rotates with the grating, this value remains the same in any position of the table. At the same time, the procedure described above adjusts the observation tube at the infinity.

3. Adjust the collimator to the infinite distance and adjust the slit width. To do this, keep the observation tube untouched in the position found in the step 2; loosen the clamping screw **6** (Fig. 563.2 (left)), and rotate the grating until the zero-order maximum (bright white reflection of the illuminated slit) appears in the field of view of the observation tube. Then tighten up the clamping screw **6** again. Adjust the focus of the collimator to obtain a clear image of the zero-order maximum. Make the slit **2** as narrow as possible using the screw **2**, so that its image is a thin but still bright enough line.

4. Superpose the vertical line of the ocular's crosshair with the image of the zero-order maximum, and take the corresponding reading of γ_0 . Slowly and accurately rotate the tube to the left (so that the angle between the collimator and observation tube decreases); find the first spectral line ($m = 1$) in the first-order maximum, superpose it with the crosshair and take the reading γ_1 again. The line may look blurred due to chromatic aberration; in this case, adjust the focus. Repeat this operation with all lines of different colours visible in the first-order spectrum. Calculate:

$$|\psi| = |\gamma_N - \gamma_0|, \quad |\varphi_1| = |\gamma_N - \gamma_1|, \quad |\varphi_2| = |\gamma_N - \gamma_2| \quad \dots \quad |\varphi_n| = |\gamma_N - \gamma_n|.$$

5. Determine the wavelengths of all observed spectral lines using the Eq. (563.1).

Questions

1. Wave interference. What is an interference pattern?
2. Coherent wave sources.
3. Geometric path difference. What path difference provides the maximum/minimum resulting intensity of two interfering waves?
4. Diffraction.
5. The Huygens's principle. Definition of the Fresnel zone.
6. Condition of the diffraction maximum of order m for diffraction at a slit.
7. In what sense geometrical optic is called a limit case of the wave theory? Write the conditions under which this approximation is true.
8. Why is the use of diffraction gratings preferable to prisms in spectral experiments?
9. Conditions of zero order maxima in grating diffraction. How does the light intensity in the principal maxima depend on the total number of slits?
10. Subsidiary (side) maxima in diffraction at a grating (explain and write the condition).

Appendix

Table A1. Resistivity of some materials

Material	Resistivity at 20°C, $\Omega \cdot \text{mm}^2/\text{m}$
Silver	0.016
Copper	0.017
Aluminium	0.028
Iron	0.093
Constantan (Cu 58.8%, Ni 40%, Mn 1.2%)	0.44–0.52
Nichrome (Ni + Cr)	1.0–1.1
Graphite	8.0

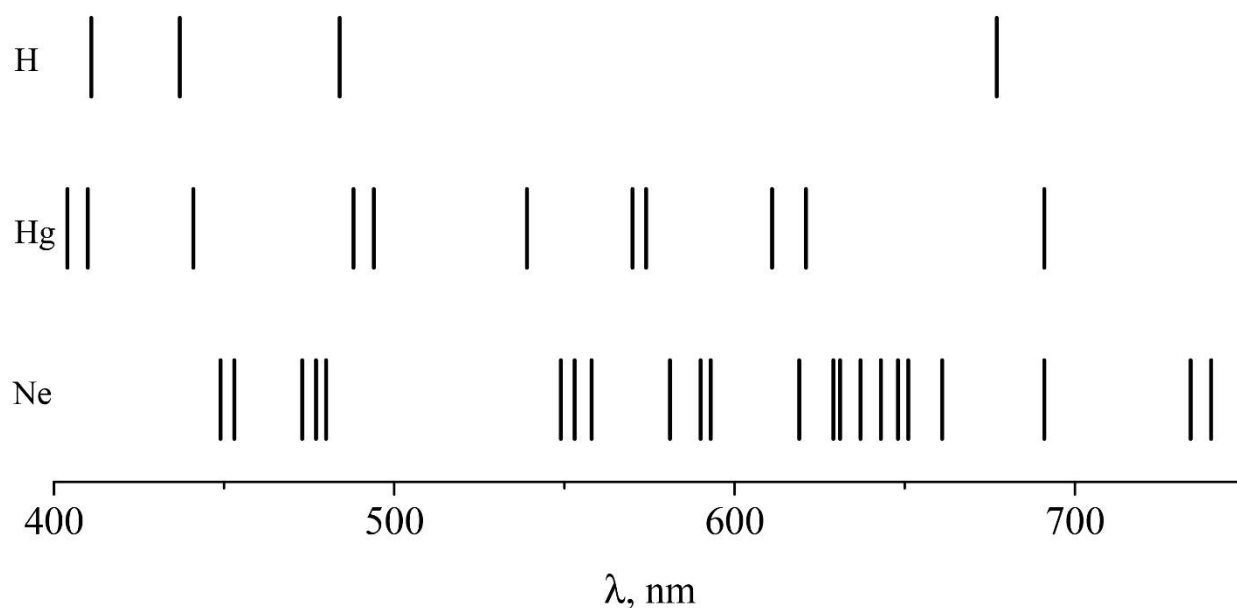

Figure A1. Examples of optical spectra of some materials in gaseous form. Remember that representation of colours in the printed book may differ from what you see in a real spectrometer!

Подписано в печать