

# THE MOBILE EXPERIMENTAL COMPLEX FOR STUDYING OF ELECTROMAGNETIC FIELDS GENERATED IN INDUSTRIAL SYSTEMS

*V.Yu. Belashov, KFU, Kazan, Russia, vybelashov@yahoo.com*  
*A.I. Asadullin, Private Company, USA, arturasadullin@gmail.com*

## 1. Introduction

The study of electromagnetic (EM) fields generated by electrical equipment and elements of electric power systems occupies an important place in the problem of electromagnetic compatibility (EMC). It is believed that the electromagnetic environment in energy and industrial companies is directly proportional to their installed power.

Study of the structure of space-time and spectral characteristics of EM fields and interferences generated by electrical equipment and individual elements of electric power systems (EPS), such as e.g. power lines, switching devices, receivers and transmitters of electricity low and high voltage, is important both 1) for the optimal design, in terms of electromagnetic compatibility (EMC) and noise immunity of electrical devices, and EPS and their individual structures to ensure sustainability of the systems and their components, and 2) to prevent accidents associated with the failure or abnormal mode of operation of electrical equipment by examining the effects of EM fields on biological objects, and therefore, life safety problems in EPS (for example, in defining and clarifying the boundaries of sanitary zones for EM field). The range of frequencies generated by the above-mentioned objects of EM radiation is estimated to be from 50 hertz (Hz; the power frequency) up to tens or hundreds of megahertz (MHz).

Therefore, studies aimed at investigating in real time the space-time structure of EM fields in a wide range of frequencies are quite relevant. It should also be noted that in the past two decades, special attention has been paid to the problem of EMC in an industrial environment in a number of international scientific organizations such as Union Radio-Scientifique Internationale (URSI) and Institute of Electrical and Electronic Engineers (IEEE).

As a result of the analysis of the available information, it has been revealed that the currently existing means of measuring EM fields can not provide a comprehensive approach to the study of EM environments in a wide frequency range for fields generated by different sources. Current methods mainly focus on one-step fixed frequency values of the EM fields. The equipment that is intended to measure EM fields to higher frequencies (often quite expensive) cannot provide, in particular, 1) a continuous digital recording process, computing in real-time, and graphical visualization of the correlation and the spectral characteristics of the detected EM processes (including the temporal dynamics of the spectrum), 2) and the opportunity to control the experiment in the process of its execution

through a flexible user interface. Consequently, the research conducted using the existing means of measuring EM fields cannot objectively assess the EM situation in general [1-3].

Based on our analysis of the existing means of measuring EM fields, we formulated the basic requirements of the equipment to be developed and elaborated its architecture. We made a detailed elaboration of the characteristics of the structural elements and their interaction algorithms, a selection the specific components (based on the relevant market research), and the assembly of the equipment with the harmonization of the functioning of the components [4].

The paper presents the mobile experimental complex for studying of electromagnetic fields generated in a wide frequency range in an industrial environment developed on a base of the Kazan Federal University and the Kazan State Power Engineering University. It describes the architecture and structure of the equipment and some of the results of monitoring studies of EM environments at two energy and industrial sites.

## **2. Architecture and structure of the equipment of the mobile experimental complex**

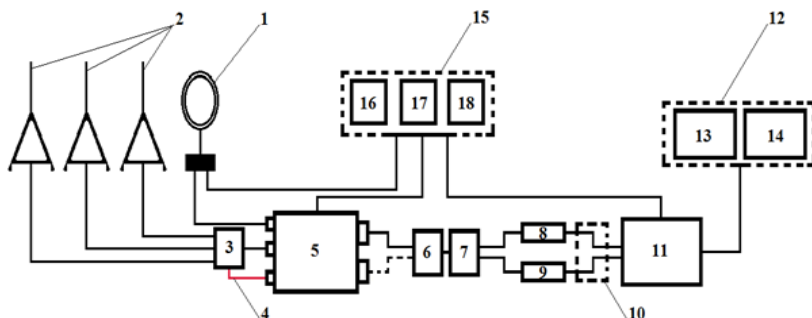
The mobile experimental complex is designed for the automated recording in a wide frequency range of the electric and magnetic components of the EM field with the possibility of computer processing and analysis of information from the field in real time, as well as graphical visualization of experimental results.

Its basic design characteristics are a compact, mobility and autonomy. The complex has a wide frequency range (5 kHz - 3 GHz), provides automated recording, and processes data in real time.

The composition of the experimental complex (Fig. 1) includes [5-8]:

- 1) magnetic antenna;
- 2) antenna system, consisting of three electrical antennas;
- 3) unit of switching electrical antenna SA-5000;
- 4) chain of control of switching antennas;
- 5) wideband receiver is type AR-5000A;
- 6) unit of switching outputs of the receiver;
- 7) unit of switching ADC;
- 8) multi-channel high-speed module with ADC and DAC E14- 440;
- 9) multi-channel high-speed module with ADC and DAC E20- 10;
- 10) programmatic demultiplexer;
- 11) computer with packages for correlation and spectral information processing, as well as package for graphical visualization of results recording and analysis which work under the control of the interactive program;
- 12) synchronization system of the complex over time;
- 13) GPS (GPRS) receiver;

- 14) rubidium frequency standard;
- 15) power supply system of the complex;
- 16) the electric network with 220 V (via adapter 12 V);
- 17) diesel generator of electricity;
- 18) battery of large capacity.



**Fig. 1. Structural diagram of the mobile experimental complex.**

Taking into account the goals and objectives of the research, we developed the software "Supervisor" designed to control the experiment to detect EM fields. It also includes application software, which is focused on the complex processing of experimental data in real time and operates by testing a series on stationarity, by filtering, by smoothing, and by calculating of the statistical parameters of samples. The algorithmic structure of the data analysis system is focused on the complex processing of experimental information. Data analysis includes the construction of the amplitude and phase spectra, and the power spectrum, and the calculation of auto- and cross-correlation functions (ACF and CCF) of convolution, and so on, in which all procedures are implemented as modules that perform the necessary conversions using a Cooley–Tukey Fast Fourier Transform (FFT) algorithm [9, 10].

The dialog window is divided into two areas. The left half of the working window "Supervisor" is an area of experiment control. In its upper part buttons functional configuration of the software module are located for solving relevant problems of correlation and spectral analysis.

The input windows of the parameters of detected signal realizations (number of blocks, the file name, and the frequency of the input data) and control buttons (start- stop recording, rewind the recorded information, and a reset button) located in the lower part of this area. In the right part of the working window is the area of visualization of measurement results, which has two graphics windows. Each window has the ability to individual adjusting for the conclusion of graph-

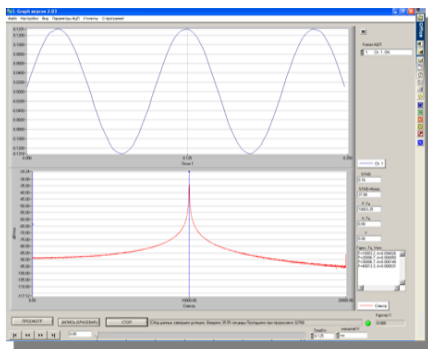
ical information.

Software modules “Supervisor” consist of the following components:

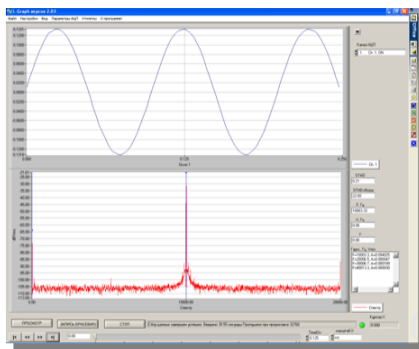
- 1) program of recording the data array in RAM or hard disk;
- 2) program of testing on stationarity;
- 3) program of processing non stationary series;
- 4) program of conducting spectral analysis;
- 5) program of conducting correlation analysis.

Testing of algorithms and processing programs “Supervisor” conducted as on the signals sent from the generator (sinusoidal signals and signals representing a superposition of several harmonic components) well as on artificially generated digital sequences (software) of the form  $X(h)=\exp(-ih)$ ,  $i=0,1,\dots$

Some examples of the test results are shown in Figs. 2–4.



**Fig. 2. Testing software package (signal with frequency 10 kHz and its amplitude spectrum, built without the use of spectral windows).**



**Fig. 3. Testing software package (signal with frequency 10 kHz and its amplitude spectrum, built using a Blackman-Harris spectral window).**

This testing has allowed to define high figure of merit of the mobile experimental complex.

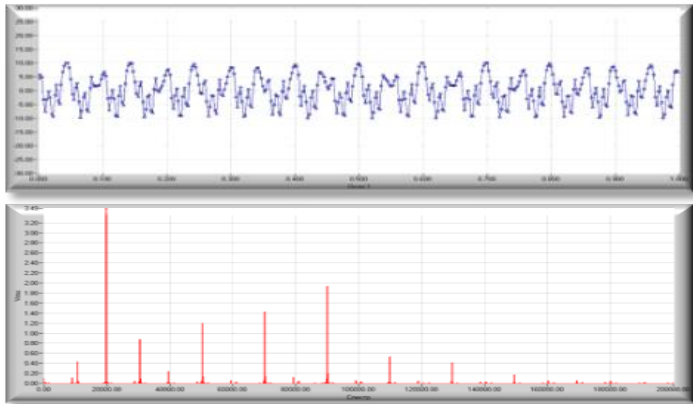
### **3. The test results of the mobile experimental complex in an industrial environment**

The final stage of creating a mobile experimental complex was its testing in an industrial environment.

In 2012-2015, we conducted experimental monitoring studies of the EM environment in a number of energy and industrial companies in the Kazan agglomeration of the Russian Federation.

Based on the our redesigned program of experiment, we conducted the continuous recording of the electric and magnetic fields in the frequency range of 5

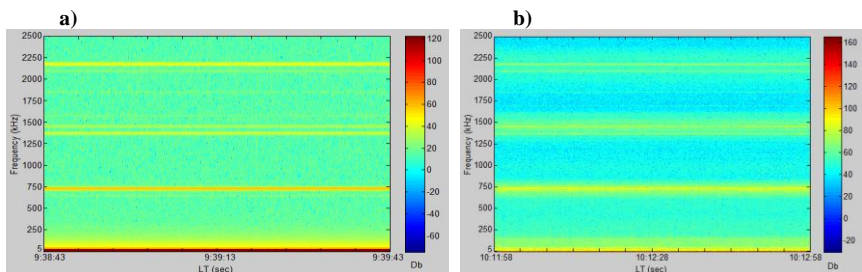
kHz – 2.5 GHz in amplitude and frequency demodulation modes. Concurrently, we controlled the temporal dynamics of the amplitude and phase spectra, as well as of the autocorrelation function of the investigated process in real time.



**Fig. 4. Testing software package (signal with frequency 20 kHz with interferences in the form of higher harmonics and its amplitude spectrum).**

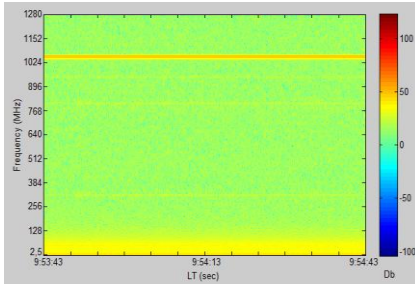
Figs. 5–7 show examples of the results of measurements of the EM field on electrical substation "Airport" (Kazan city).

By orienting a magnetic antenna at an azimuth angles  $0^\circ$  (Fig. 5a) and  $90^\circ$  (Fig. 5b) to the direction of the power equipment of the substation, we observed powerful radiation (in low-frequency ranges) on frequencies of 700 kHz ( $\sim 100$  dB),  $\sim 1300$  kHz ( $\sim 40$  dB),  $\sim 1450$  kHz ( $\sim 45$  dB) in amplitude demodulation mode.

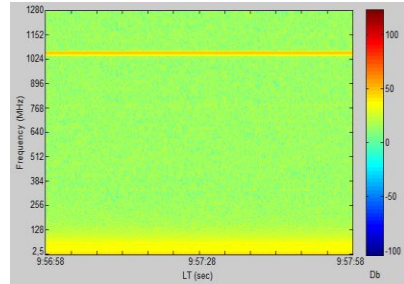


**Fig. 5. Dynamic spectra (5 kHz – 2.5 MHz). Amplitude demodulation. Magnetic antenna: a) orientation  $0^\circ$ ; b) orientation  $90^\circ$ .**

In the high-frequency range 2.5 – 1280 MHz, we observed sufficiently powerful radiation on frequency  $\sim 1100$  MHz ( $\sim 100$  dB) modulated both by amplitude (Fig. 6) and by frequency (Fig. 7).



**Fig. 6. Dynamic spectrum (2.5 MHz – 1.28 GHz). Electrical antenna. Frequency demodulation.**



**Fig. 7. Dynamic spectrum (2.5 MHz - 1.28 GHz). Electrical antenna. Amplitude demodulation.**

Presumably, the source of this high-frequency radiation was the navigation system of the Kazan airport.

It is also possible that the high voltage electrical equipment of the substation contributed to the overall EM picture.

Figs. 8–9 show examples of the results of measurements made on the territory of the open joint stock company "POZIS".

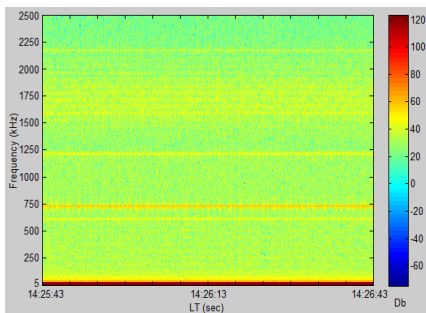
According to reports, the company management area contains the following electricity-consuming equipment: electric motor frequency converters GFW-0,

9110 kW; VLT-8252 160 kW; and TPCH-320-05/160-04; a low-temperature annealing machine (ANO); and an annealing and quenching machine (AOZ). All these electricity consumers radiate EM fields in a wide range to a hundred MHz [4].

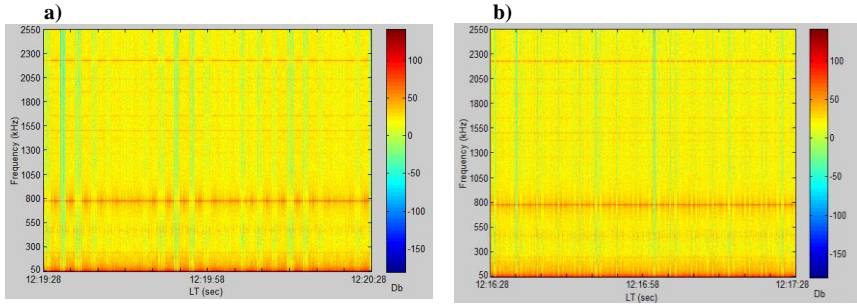
Fig. 8 shows that, in addition to the harmonics of industrial frequency over the entire range of measurements, there was radiation on frequencies ~ 600 kHz (-50 dB), ~ 750 kHz (-90 dB), ~ 1200 kHz (-50 dB),

and ~ 2200 kHz (~ 50 dB). A similar pattern was observed frequency demodulation mode.

We observed that when measuring the EM environment (company management area) with electrical antenna in frequency demodulation mode in the high-frequency range (2.5 MHz – 1.28 GHz), powerful EM radiation was not observed.



**Fig. 8. Dynamic spectrum (5 kHz - 2.5 MHz). Electrical antenna. Amplitude demodulation.**



**Fig. 8. Dynamic spectra of the electric field strength near step-down transmission substation: a) frequency demodulation; b) amplitude demodulation.**

Apparently, this is due to the fact that there is no established electrical equipment operating in the high-frequency range in this area of the company.

Fig. 9 shows the results of similar measurements near the step-down transmission substation of the company - the dynamic spectra of EM radiation of the received signal, recorded in both the amplitude and frequency demodulation modes, was in the range of 50 – 2550 kHz. The most powerful electrical equipment in this sector of the company was the cable power lines (10 kV), transformers TMS-2500/10, and high-voltage switches 100SFMT-40E.

From the comparison of results in Fig. 9, we can, in particular, conclude that the generated radiation of the cable network (10 kV) and power electrical equipment mounted on the step-down transmission substation of the company, modulated both by amplitude and by frequency, presumably determined quite a complex space-time structure and dynamic of the EM field near the high-power objects. We observed that besides transformers, switches, and cable high-voltage lines, electricity-consuming equipment placed in the nearby departments of this company made some contribution in the spectrum of EM radiation. For example, electric motors the boiler room for frequency converters MFC710 55 kW and the quenching machine LZ-107, generated EM fields in the frequency range of 5 kHz - 900 MHz [4].

#### 4. Conclusions

As a result of the series of performed experiments, we can conclude the following:

1. The total effect of impact of a large set of sources on EM environment around real objects of energy and industry.
2. When using our results (it had the main purpose of testing the equipment and software of the complex in actual field conditions), it was not possible to draw a clear identification of the conditionality of each specific spectral line or band with a specific source.

3. For solving the problem of establishing the sources of radiation of EM fields in specific frequency bands, a specially trained purposeful large cycle of experimental studies is required for each facility, including multi-antenna direction-finding measurements. Characteristics of the complex allow us to conduct such measurements [11, 12].

Overall, the results obtained in our experiments characterize the general EM environment associated with the presence of EM radiation in a wide frequency range from 5 kHz up to 2500 MHz. These results can be useful both when commissioning new electrical equipment, systems of relay protection and automation, and communication and control, and when the operating already existing electrical equipment for solving problems of EMC and for taking appropriate measures to ensure the safety of personnel.

### References

1. **Belashov V.Yu.** Electromagnetic fields and interferences in the EPS of industrial enterprises // Russian National Symposium on Energy, Kazan, 2001.
2. **Diakov A.F., Maksimov B.K., Borisov R.K.** etc. Electromagnetic compatibility in power generation and electrical. M: Energoatomizdat, 2003.
3. **Diakov A.F., Kuzhekin E.P., Maksimov B.K.** etc. Electromagnetic compatibility and lightning protection in the power. M: MPEU, 2009.
4. **Asadullin A.I., Belashov V.Yu.** Study of EM fields generated by electrical equipment and by elements EPS. Part 1. Typical sources of EM fields in EPS . Means for measuring electromagnetic field // News of universities. Energy problems. 2011. № 11-12.
5. AOR AR5000A. Professional radio communicative receiver. The user's guide. Firm «Sicom», 2003.
6. HI-Q active loop aerial. LA380. Instruction Manual. E&OE AOR LTD, 2005.
7. E14-440. External module ADT/DAT/TTL for general purpose on the trunk USB 1.1. The user's guide. Moscow, L-Card, 2008.
8. E20-10. External module ADT. The user's guide. Moscow, L-Card, 2010.
9. **Asadullin A.I., Belashov V.Yu.** Study of EM fields generated by electrical equipment and by elements EPS. Part 2. Mobile experimental complex for the study of electromagnetic fields in a wide frequency range // News of universities. Energy problems. 2012. № 1-2.
10. **Belashov V.Yu., Belashova E.S., Asadullin A.I.** Testing the time series for stationarity in systems for processing of experimental data // Radiophysics and Quantum Electronics. 2013. V. 55. Is. 9.
11. **Belashov V.Yu., Asadullin A.I.** Mobile experimental complex for the study of electromagnetic fields generated by electrical equipment and components of electric power systems // Industrial Energy. 2012. № 8.
12. **Belashov V.Yu., Asadullin A.I.** The mobil experimental complex for studying of electromagnetic fields generated in a wide frequency range in an industrial environment // Proc. 2014 Intern. Symp. on Electromagnetic Compatibility (EMC Europe 2014), Gothenburg, Sweden, Sept. 1-4, 2014.