



12th International Strategic Management Conference, ISMC 2016, 21-23 July 2016, Podgorica, Montenegro

Project management using the buffers of time and resources

Azar Izmailov^a, Diana Korneva^b, Artem Kozhemiakin^{c,*}

^{a,b} *Kazan (Privolzhsky) Federal University, Street Kremlevskaya 18, Kazan, 420008, Russia*

^c *TOC team consulting, Street Moskovskaya 25/29, Kazan, 420111, Russia*

Abstract

One of the reasons to distinguish project management as a separate field of knowledge is the uncertainty. The way we manage the uncertainty in the project (and risk management in particular), has direct influence on the project duration and its success. According to multiple studies performed for the traditional project management methods, only 44% of the projects finish in time. 70% of the projects reduce the amount of planned work, 30% of the projects simply die unrealized. Even so nowadays, with new tools and techniques, that numbers tend to decrease, the overall picture says that we, as a project manager, perform our work poorly. This article examines the use of a relatively new method of project management, Critical Chain Project Management (CCPM), comparing it with the traditional approach to project management.

© 2016 The Authors. Published by Elsevier Ltd.

Peer-review under responsibility of the organizing committee of ISMC 2016.

Keywords:

Project management, Critical Chain Project Management (CCPM), Theory of Constraints (TOC), Buffer, Parkinson's Law, Critical path ;

* Corresponding author. Tel.: +7-917-911-83-73; fax: +7-843-514-80-81.

E-mail address: azar@tocteam.ru

1. Introduction

Nowadays there is a method applicable to monitor changes and uncertainties - the Critical Chain Project Management method (CCPM). It does not focus on separate tasks, but it focuses on the only important date - the project completion date.

CCPM is a planning and project management method that focuses on the project resources limitations. It was proposed and developed by Eliyahu Goldratt in 1997. This method's approach is opposite to the PERT (Project Evaluation and Review Technique) in the sense that it does not propose neither rigid tasks sequence nor rigid plan. On the contrary, the plan prepared in the terms of CCPM consists of the time-equalized resource load. However, it requires some flexibility in the tasks start time and fast switching between them (without working on them simultaneously) in order to keep project in its time borders.

Perhaps the most difficult task which project managers need to solve on the daily basis is to keep dynamic project in initial schedule. Limited resources and growing qualification requirements in difficult projects leads to resource limitation becoming the most important factors of risk on the way of project successful completion. In order to review how that kind of risk affects the project schedule project leads trained to focus on the tasks on the critical path of the project. They also know, that resources involved in that tasks need to be managed proactively. This requirement is especially important in relation to the resources involved in the external projects of the company.

That is the situation when CCPM helps project lead to plan and manage project schedule with the dedicated optimization tool, which combines the critical path of the connected project tasks with the critical path of the resources used in that tasks. And that connection directly affects the project completion date. The critical chain of the project clearly defines the array of the project tasks that needs their resources to be aligned. If the amount of the resources in the project was infinite, the critical path and the critical chain of the project would be the same.

Unfortunately, actions focused on aligning of the resources related to the critical chain of the project often leads to the project later completion time. On order to complete the project in time the new schedule should be optimized. The critical chain optimization as well as the critical path optimization is a task, where you need to reduce the duration. The difference is that the CCPM also focuses on the resources of the project, aligning them with early start and fast switching between tasks.

CCPM optimization defines that the reserves, included in the project estimated execution time, may not be required, and, in theory, all project tasks may be completed earlier than estimated. Here we should take into account that despite of the individual tasks time reserves, there is no big chance to significantly reduce project duration at their expense. On the other hand, if we reduce individual tasks reserves, the delay of the only one task may result in the overall project delay.

2. Literature Review and Hypotheses

With a traditional approach to project management, problems related to the uncertainty (the Murphy's law), the Parkinson's law, and simultaneous work on the several different tasks could be solved using the following approaches.

2.1. Including risks and uncertainty into the project task estimates

Often both the employee and his boss tends to include into the project estimates risks and uncertainty they see. Uncertainty for example may be connected to the various factors like new technology, low level of employee experience, lack of knowledge about the task and inability to accurately estimate its duration. They try to minimize risks adding some reserve time to each task estimated duration. Because each task completion time is represented as a probability distribution, not as a constant, the graphical representation of the task estimated duration in the terms of traditional project management it has been shown at Figure 1 below:

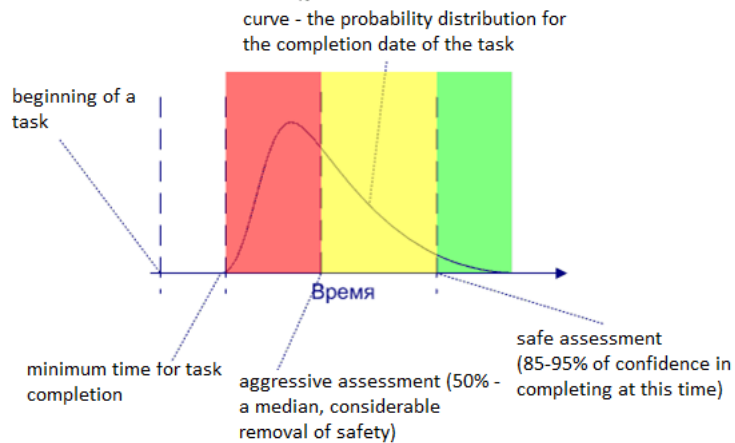

Fig. 1. Time of the completion of a task as distribution of probability.

The risks are included into the task estimate in order to minimize Murphy's law influence. And even so this estimate is done by the experts and contractors (and that is good and right), extra time is often added roughly.

That way, nearly every task contains time reserve exceeding the actual completion time estimate. Often you can see that the risks estimate may exceed the implementation time itself.

On the part of the employee this leads to the following negative consequences. In fact, this is an example of so-called "student syndrome": when the worker see that he has extra time and decide to start working later. That way the resources focus on the more urgent tasks or spend their time reserve to work on the task itself, thinking that all time is dedicated to it. And, as a result, if the predicted risks trigger, the task delays.

2.2. Focus on the estimated start and end date of the task

With a traditional approach to the project management people tend to begin end task exactly within the estimated borders. This estimated time imposes an obligation on the contractor's.

This approach seems right at the first sight but it has some significant drawbacks and does not allow to use possible positive project events.

At first, early task completion does not lead the project early completion. Contractors, that should start their tasks execution could not do this because they are busy working on some other job and they did not expect to start working on their tasks before the initially scheduled time. As a result, the early task completion can not boost the dependent tasks and positively affect the overall project success.

At second, the delay of the task always leads to the delay of the dependent tasks, because all of the risks were initially included in every separate task (see Figure 2).

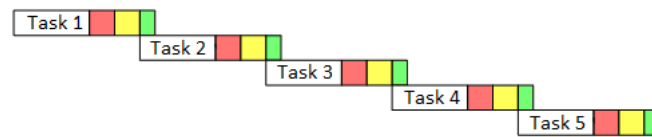

Fig. 2. Tasks having a substantial reserve in time, are planned, one after another.

In the case of a time shift the typical solution of the traditional project management is to apply the adjustment by cutting the initial amount of work and/or allocating extra resources. This does not make happy neither customer nor top-managers.

3. Methodology

CCPM introduces such definition as a tasks critical chain, or critical chain simply speaking. Critical chain is a sequence of tasks, which duration affects the overall duration of the project. It means that CCPM proposes to concentrate on the only important date: the date of the project completion.

CCPM eliminates previously mentioned drawbacks of the traditional project management planning, execution and monitoring.

3.1. Eliminating Parkinson's law

Remember that Parkinson's law means that any work will take all of the time dedicated to it, no matter how much reserve time you will allocate on it.

The work of the resources on the task in the traditional project management takes all the time dedicated to it because of the combination of the following reasons: existence of a rigid completion date and "safe" time estimates which include time reserves.

To eliminate this problem CCPM propose the following:

- Build the schedule using pretty dense tasks duration estimates. Usually CCPM suggests to take estimate with a 50% risk coverage, so called "aggressive estimate" .
- Eliminate the usage if a rigid tasks completion dates (tasks, but not project). Certainly, tasks duration still need to be estimated, however it should not be treated as if the contractors must finish their work exactly in time.
- In matrix organizational structure it makes sense to give managers enough power for them to be able to protect project resources from the "more urgent" tasks of the other projects or departments.

Let's see what all of that rules give to us. Because tasks are estimated with a 50% risk coverage, CCPM requirement to build the schedule using only that amount of time needed to actually complete the tasks is fulfilled. And, because we removed additional safety requirement from the tasks estimates, there is no more need to treat individual tasks completion dates as something obligatory and mandatory.

That way, the described approach helps us to eliminate the Parkinson's law.

3.2. Using positive events with earlier tasks completion to achieve the overall project success.

CCPM conventionally divides all project resources into the following two categories: critical tasks resources and non-critical tasks resources. In this context, we need to primarily take care of the critical tasks related resources, because they directly affect the overall success and duration of the project. And we want to be sure that when some task on the critical path completes, the resources needed for the next task will be ready.

Two simple steps, when performed professionally, allow to use the advantage of an earlier completion for tasks in the critical chain. At first, we need to gather some information from the project resources: when they should be warned so they will have enough time to finish their current work and switch to the new, more important task of the critical chain. At second, the resources must be required to periodically give estimates of how much time they need to finish their current work ("warning buffer").

Having this information, we will be able to track when the left time estimate will become less than the contractor warning buffer and warn him to be ready to start working on his task.

Comparing with the traditional project management, it is a step from monitoring of what "was done", using the percent of the completed work (which itself is a pretty subjective indicator) to monitoring how much time we have to complete the unfinished tasks, which is really important to monitor the current status of the project.

3.3. Using time and resource buffers to prevent Murphy's law consequences.

Well, now we reduced the estimates to the minimally appropriate level, focusing on the tasks execution. Also we are using the advantage of the eventual tasks early completion. But now, when we have no rigid deadline, how could we know when the resource will be available for other tasks? And moreover, how should we deal with risks which are no longer covered with an extra time?

In order to protect the final completion date of the project from the tasks variation, CCPM uses time and resource buffers.

At first let's talk about the project buffers. In CCPM special attention is paid to the tasks on the critical chain. All that we need to do is to accumulate all chain tasks time reserves which constitutes from 50% to 90% of the uncertainty coverage leaving only 50% of the initial coverage to the tasks themselves. This scattered over all tasks reserves are accumulated to the single project buffer that we put at the end of the critical chain (see figure 3). That way, the variations in the critical chain does not directly effect on the estimated completion date of the project, because of the effect of the project buffer.

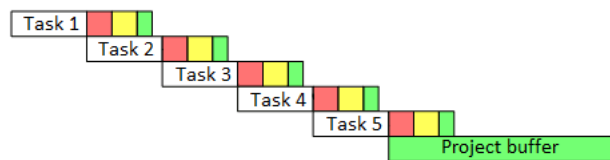

Fig. 3. Buffer placed in the end of a chain protects her from delays.

Since we keep only 50% of the risk coverage in each individual task estimate, we can expect that 50% of the tasks will be completed earlier, and 50% will be completed later than estimated. In CCPM we actively use the advantage of early tasks completion. With regard to the delayed tasks, they will be compensated by the project buffer on the end of the critical chain. Without going into statistics we can say that the accumulated buffer should be significantly smaller than the sum of the initial individual tasks time reserves (30%-50% less).

Concerning the tasks out of the critical path, we definitely do not want to micromanage each individual task and each contractor like we do it with the tasks on the critical path using warnings for the finishing tasks. However, we do not want non-critical tasks to have negative impact on the overall project success.

What does traditional tasks management approach suggest with regard to the non-critical tasks? It proposes to start working on every task as fast as you can and to believe that the amount of the reserve time dedicated to non-critical tasks will be enough to cover all potential risks. In contrast to the traditional task management, in CCPM we use not only floating time for the non-critical tasks, but also the same approach with a buffer on the end of the chain (now non-critical) that was described for the critical tasks. This buffer (let's call it "feeding buffer") protects dependent critical chains from the time variations in the non-critical chains it has been shown at Figure 4 below.

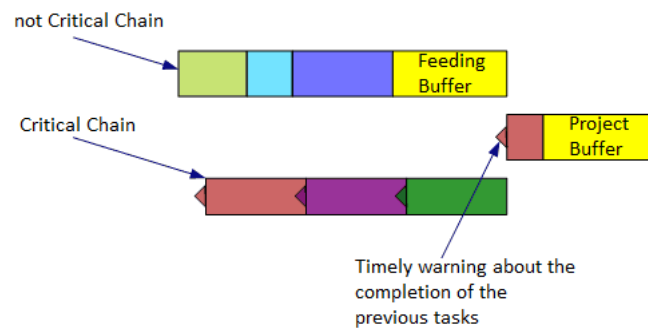

Fig. 4. Scheduling for the CCPM.

For the non-critical chain, we do not use any additional tools to avoid consequences of the possible delay (like warning about the finishing task for example). For that tasks it is enough to have double buffer: floating time and feeding buffer.

Thus, schedule building with CCPM uses feeding and project buffers, and also resource buffers (which will be described in the next section).

3.4. Using resource buffers

Resource buffer is a particularly interesting tool in the toolchain of CCPM. We can conventional distinguish two categories of the resource buffers.

First one is the time in which we need to warn the contractor that he will need to switch on some prioritized task on the critical chain.

Second type of the resource buffer is the allocation of additional resources for the tasks on the critical chain. This buffer makes sense only if the tasks may be affected by frequent changes. In that case additional resources may protect the project from the delay.

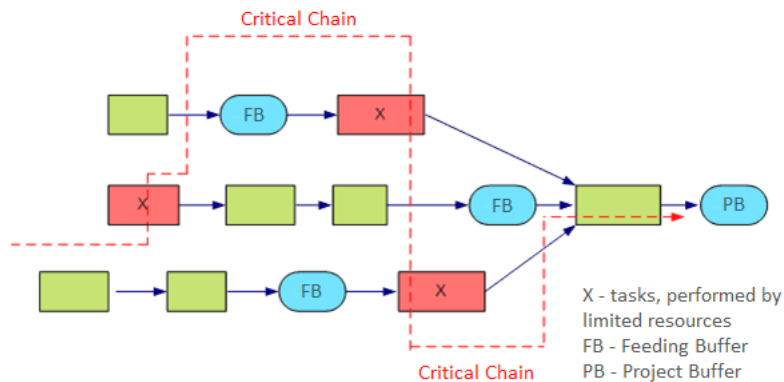

Fig. 5. Critical Chain in this case consists of tasks performed by limited resources.

On the figure 5 you can see critical chain build of the scarce resources. Accordingly, buffers used in this situation mainly used not to avoid lack of the time, but to manage risks related to that scarce resources. Feeding buffers located before the tasks related to the critical resources protect them from the time shifts in case of non-critical tasks delays.

4. Conclusion

Project progress and planning accuracy with the use of CCPM is frequently monitored not by the classical technique of earned value analysis, but by the percentage of the used buffers. Those, the more time planned as a buffer is used, the greater the impact of uncertainty on the project in the form of realized risks. Tracking remaining project buffer for the task is used in CCPM to monitor the status of the task: when achieving the minimal threshold level of the buffer you need to apply some corrective actions. Similarly, the percentage use of the project buffer serves as a trigger for determining the feasibility of the promised completion date, and the indication of the success of the project (for example, if no more than 50% of the project buffer is used, then this project may be considered as very successful).

Summing up the above, we can recommend the following set of practical steps to use CCPM:

- Explain the contractors that they have to defend their estimates of pressure from the authorities and other project stakeholders.
- Take estimated task duration with a 50% of the uncertainty coverage.
- Avoid competition for resources through load balancing. It also removes the need to switch resources between tasks. Critical chain can now be defined as the longest chain and resource dependencies.
- Paste project buffer at the end of the project to accumulate the reserve time (initially something near 50% of the critical chain duration).

- Protect critical chain of unavailability of resources, through the resource buffers.
- Calculate and arrange the feeding buffers for all paths, which critical chains are dependent on
- Plan tasks that do not depend on any other tasks from the end date of the project to its beginning. This will ensure the absence of the resource multitasking.
- Track and ensure the planned performance of the resources. Contractors need to work on tasks as quickly as possible, and to give the results of their work as soon as it is completed.
- Provide the resources with the information about the duration and estimated start time of the task, but not about the overall project stages. It should force them to give the results of their work as soon as it is completed.
- While making the project, you should actively manage time and resource buffers to minimize possible tasks delays and to keep realistic one of the main promise of the project: its estimated completion date.

Thus CCPM helps to avoid Parkinson's law and, at the same time, protects against Murphy. The overviewed method concentrates the attention of the project manager on the team's performance, offers a new method for tracking the progress of the project through the use of time and resource buffers. CCPM can be used in virtually all areas where the use of project management methodology is applicable. Also it does not require significant rebuilding of the processes in the project.

If your organization is actively using project management, including the use of a limited number of resources, and timing of projects are critical to the management, the use of critical chain project management may become your "magic wand". Naturally, like any other methodology, critical chain method will need to be adapted to the requirements of a particular company.

Critical chain method, in our opinion, may be the most effective approach to the projects planning in the last 30 years. In dozens of projects it already proved that it helps to protect project completion time from various unavoidable risks, that occur in every project.

References

- Azar Izmailov (2014). If Your Company is Considering the Theory of Constraints. *Procedia - Social and Behavioral Sciences*. Volume 150, 15 September 2014, Pages 925–929
- Azar Izmailov (2015). Effective Project Management with Theory of Constraints. *Procedia - Social and Behavioral Sciences*.
- Cather H. (1997) Is the 'critical chain' the missing link? *Project Mgmt Today*; Nov/Dec:22-5.
- Cox, Jeff; Goldratt, Eliyahu M. (1986). *The goal: a process of ongoing improvement*. North River Press. ISBN 0 88427-061-0.
- Diana Korneva, Azar Izmailov, Alia Khaliullina (2016). Throughput accounting as instrument for formation of company assortment policy. *International scientific review № 3 (13)*
- Eliyahu M. Goldratt (2004). *Essays on the Theory of Constraints*. North River Press. ISBN 0-88427-159-5.
- Eliyahu M. Goldratt (2004). *The Goal: A Process of Ongoing Improvement*, ISBN 978-0-88427-178-9. *Theory of Constraints Handbook (2005)*, ISBN 978-0-07-166554-4, p. 8
- Eliyahu M. Goldratt (2007). *Viewer Notebook: The Goldratt Webcast Program on Project Management – the strategy and tactics tree for projects 4.7.1*. Goldratt Group Publication.
- Eliyahu M. Goldratt (2008). *The Choice*. The North River Press, MA.
- Eli Schragenheim and H. William Dettmer (2000). *Simplified Drum-Buffer-Rope: A Whole System Approach to High Velocity Manufacturing*. Retrieved 2007-12-08.
- George Ellis, (2016) *Project Management in Product Development, Leadership Skills and Management Techniques to Deliver Great Products 2016*, Pages 143–175
- Ghaffari, M. and Emsley, M. (2015). "Current status and future potential of the research on Critical Chain Project Management." *Surveys in Operations Research and Management Science*, 10.1016/j.sorms.2015.10.001, 43-54.
- Goldratt EM, Cox J. (1993) *The goal*, 2nd ed. Aldershot, England: Gower. ISBN: 978-0884270614
- Goldratt EM. (1994) *It's not luck*. Aldershot, England: Gower. ISBN: 978-0884271154
- Goldratt, Eliyahu M. (1997). *Critical Chain*. Great Barrington, MA: North River Press. ISBN 0-88427-153-6.
- Hu, X., Cui, N., Demeulemeester, E., and Bie, L. (2015). "Incorporation of activity sensitivity measures into buffer management to manage project schedule risk." *European Journal of Operational Research*, 10.1016/j.ejor.2015.08.066, 717-727.
- Leach, L.P. (1999). *Critical Chain Project Management Improves Project Performance*. *Project Management Journal*, June, 39-51.
- Leach L.P. (2004). *Critical Chain Project Management*. Artech House.
- Lechler, T.G., Ronen, B., Stohr, E.A. (2005). *Critical Chain: A new project management paradigm or old wine in new bottles?* *Engineering Management Journal*, 17 (4), 45-58.
- Ma, G., Gu, L., and Li, N. (2015). "Scenario-Based Proactive Robust Optimization for Critical-Chain Project Scheduling." *Journal of Construction Engineering and Management*, 10.1061/(ASCE)CO.1943-7862.0001003, 04015030.

- Newbold, R.C. (1998). *Project Management in the Fast Lane – applying the theory of constraints*. St Lucie Press.
- Newbold R.C. (2008). *The Billion Dollar Solution; Secrets of Prochain Project Management*. ProChain Press.
- Paul H. Selden (1997). *Sales Process Engineering: A Personal Workshop*. Milwaukee, WI: ASQ Quality Press. pp. 33–35, 264–268. ISBN 0-87389-418-9.
- Pawan, P. and Lorterapong, P. (2015). "A Fuzzy-Based Integrated Framework for Assessing Time Contingency in Construction Projects." *Journal of Construction Engineering and Management*, 10.1061/(ASCE)CO.1943-7862.0001073, 04015083.
- Raz, T., Barnes, R., Dvir, D. (2003). A Critical Look at Critical Chain Project Management. *Project Management Journal*. Dec, 24-32
- Shanlin Yang, Lei Fu (2014). Critical chain and evidence reasoning applied to multi-project resource schedule in automobile R&D process. *International Journal of Project Management*, Volume 32, Issue 1, January 2014, Pages 166-177
- Steyn, H. (2000). *An Investigation into the Fundamentals of Critical Chain Project Scheduling*.
- Steyn, Herman (2009). "An Investigation Into the Fundamentals of Critical Chain Project Scheduling.". *International Journal of Project Management* (19): 363–369.
- Tsai-Chi Kuo, Sheng-Hung Chang, Shang-Nan Huang (2009). Due-date performance improvement using TOC's aggregated time buffer method at a wafer fabrication factory. *Expert Systems with Applications*, Volume 36, Issue 2, Part 1, March 2009, Pages 1783-1792